

Instruction Manual

Model CXT-DM

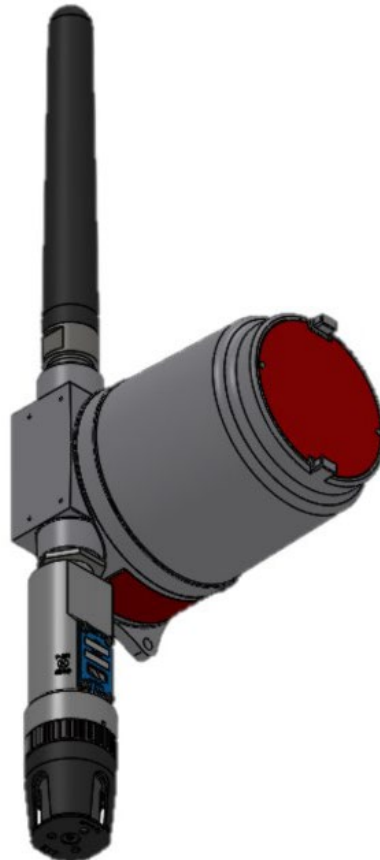

CXT-DM Toxic Gas Sensors

CXT-DM O2 Deficiency Sensors

This manual covers all CXT-DM Sensors



Use and Disclosure of Data

Information contained herein is classified as EAR99 under the U.S. Export Administration Regulations. Export, reexport or diversion contrary to U.S. law is prohibited.

This page left intentionally blank

Table of Contents

1.	Introduction.....	1
1.1	Description.....	1
1.2	Modular Mechanical Design.....	2
1.2.1	CXT-DM Intelligent Transmitter Module.....	3
1.2.2	Field Replaceable Sensor	3
1.3	CXT Wireless Network	3
1.4	Battery Pack Options.....	4
1.4.1	Teledyne Detcon’s Smart Battery Pack.....	4
1.4.2	D Cell Lithium Battery Pack	5
2.	Installation.....	6
2.1	Hazardous Locations Installation Guidelines for Safe Use	6
2.2	Sensor Placement	7
2.3	Sensor Contaminants and Interference	8
2.4	Sensor Mounting.....	8
2.5	Electrical Installation.....	9
2.5.1	Applying Power to the Unit.....	10
2.6	Initial Start Up	11
2.6.1	Toxic Gas Sensors.....	11
2.6.2	O ₂ Deficiency Sensors	12
3.	Operation	13
3.1	Operator Interface	14
3.2	Normal Operation	15
3.3	Calibration Mode	15
3.3.1	AutoZero	16
3.3.2	AutoSpan.....	16
3.4	Program Mode	18
3.4.1	Navigation Program Mode	18
3.4.2	View Sensor Status	18
3.4.3	Set Detection Range.....	19
3.4.4	Set Autospan Level.....	19
3.4.5	Bump Test	20
3.4.6	Restore Defaults.....	20
3.4.7	Set RF Channel.....	21
3.4.8	Alarm Settings	21
3.4.9	Set Modbus ID.....	21
3.5	Fault Diagnostic/Failsafe Feature	21
4.	Modbus™ Communications	22
4.1	General Modbus™ Description.....	22
4.1.1	Modbus™ Exceptions	22
4.1.2	Modbus™ Broadcast Request.....	23
4.2	Modbus™ Register Map & Description	23
4.2.1	CXT Sensor Registers	25
4.2.2	CXT Transceiver Registers	26
5.	Service and Maintenance	28
5.1	Replacement of the batteries/battery pack.....	28
5.1.1	Units with 12V Smart Battery Pack.....	28
5.1.2	Units with D-size Non-Rechargeable Batteries	28
5.2	Replacement of Plug-in Sensor.....	29
5.3	Replacement of ITM – Aluminum J-Box.....	30
6.	Troubleshooting Guide	31
7.	Customer Support and Service Policy	33
8.	CXT-DM Sensor Warranty	34
9.	Appendix.....	35

9.1	Specifications	35
9.2	Sensor Specification Data	36
9.3	Interference Table	37
9.4	Spare Parts, Sensor Accessories, Calibration Equipment	43
10.	Revision Log	44

Table of Figures

Figure 1	Sensor Assembly with J-Box and Smart Rechargeable Battery Pack	1
Figure 2	Construction of Electrochemical Toxic Sensor	2
Figure 3	Construction of Galvanic Cell	2
Figure 4	Sensor Assembly Breakaway	2
Figure 5	Functional Block Diagram	3
Figure 6	Plug-in Sensor	3
Figure 7	Smart Battery Pack	4
Figure 8	Quad Battery Charger	5
Figure 9	D-Cell Lithium Battery Pack	5
Figure 10	CXT-DM Sensor with D or Smart Battery Pack Mounting Dimensions	9
Figure 11	Terminal Interconnect for Smart Battery Pack	11
Figure 12	Magnetic Programming Tool	13
Figure 13	Magnetic Programming Switches	13
Figure 14	Menu Flow Chart	15
Figure 15	Modbus™ Frame Format	22
Figure 16	Battery Orientation Diagram	29
Figure 17	Sensor Cell and ITM Mating	30

List of Tables

Table 1	Exception Codes	23
Table 2	CXT-DM Register Map	24
Table 3	Sensor Specific Data	36
Table 4	Interfering Gases	37
Table 5	Cross Interference Table	38

Shipping Address: 14880 Skinner Road, Cypress, Texas 77429
 Phone: 713.559.9200

<http://www.teledynegasandflamedetection.com> • detcon-sales@teledyne.com

1. Introduction

1.1 Description

Teledyne Detcon Compact Wireless Sensor Model CXT-DM toxic gas and O₂ deficiency sensors are non-intrusive wireless sensors designed to detect and monitor a wide range of toxic gases in air. The unit is designed to work as part of a wireless network of gas sensors and communication is performed via a built-in RF transceiver. Ranges of detection for toxic gases are from 0-1ppm up to 0-10,000ppm; typical ranges of detection are 0-10ppm, 0-25ppm, 0-50ppm and 0-100ppm. Ranges for O₂ deficiency are 0-1% up to 0-25% by volume. The basic sensor assembly consists of an electrochemical sensor mounted in Intrinsically Safe stainless steel housing and includes a Splash Guard Cal Adapter. The sensor is installed on an explosion proof junction box with a choice of battery pack options making operation fully independent of outside cabling. Other options are available, contact Teledyne Detcon for more information.

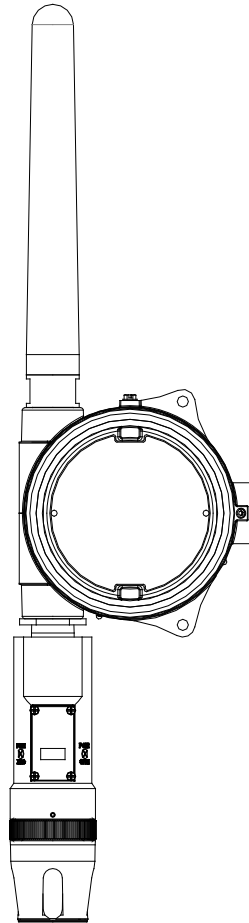

Figure 1 Sensor Assembly with J-Box and Smart Rechargeable Battery Pack

Electrochemical Sensor Technology

The Toxic gas sensors are based on electrochemical cells. Each cell consists of three electrodes embedded in an electrolyte solution all housed beneath a diffusion membrane. Sensitivity to specific target gases is achieved by varying composition of any combination of the sensor components. Good specificity is achieved in each sensor type. The cells are diffusion limited via small capillary barriers resulting in a long service life of up to three or more years. The electrochemical cell is packaged as a field replaceable plug-in sensor.

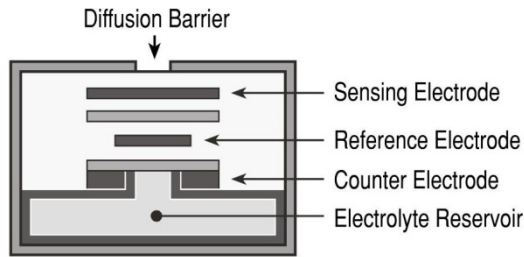

Figure 2 Construction of Electrochemical Toxic Sensor

The O₂ deficiency sensor technology is a two electrode galvanic metal air battery type cell, which is housed as a field replaceable intelligent plug-in sensor. The cell is diffusion limited and functions as a direct current generator proportional to the amount of oxygen adsorption. The sensors are temperature compensated and show good accuracy and stability over the operating temperature range of -20° to +50°C (-4° to +122° Fahrenheit). The sensor is warranted for two years and has an expected service life of up to 2.5 years in ambient air at 20.9% oxygen.

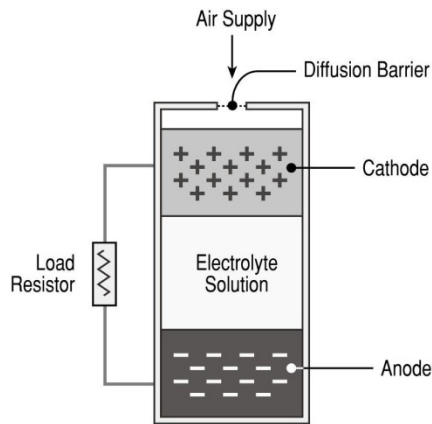

Figure 3 Construction of Galvanic Cell

1.2 Modular Mechanical Design

The Model CXT-DM Sensor Assembly is completely modular and is made up of four parts (See Figure 4 for Assembly Breakaway):

- 1) CXT-DM Intelligent Transmitter Module (ITM)
- 2) Plug-in Electrochemical Sensor (varies by gas type and range)
- 3) CXT Series Bottom Housing
- 4) Splash Guard.

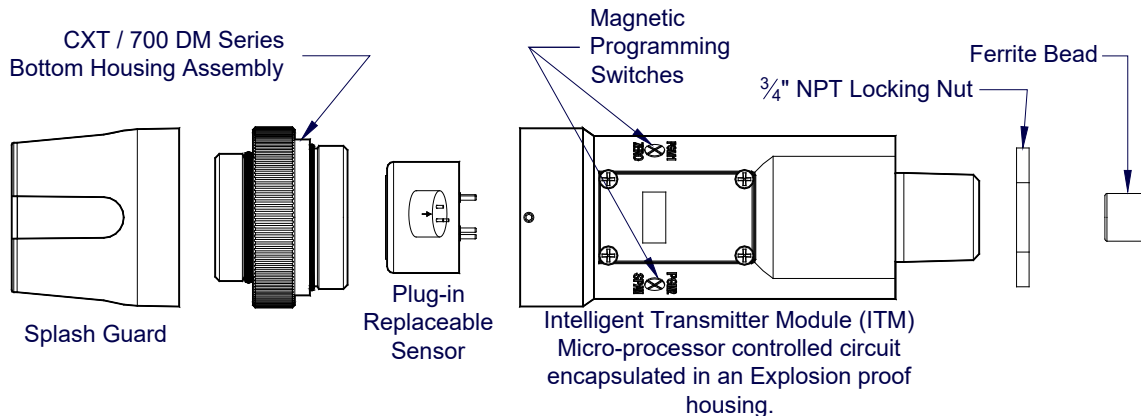

Figure 4 Sensor Assembly Breakaway

NOTE: All metal components are constructed from electro polished 316 Stainless Steel in order to maximize corrosion resistance in harsh environments.

1.2.1 CXT-DM Intelligent Transmitter Module

The Transmitter Module is a microprocessor-based package that is attached to the explosion proof junction box. Circuit functions include an intrinsically safe barrier, on-board power supply, microprocessor, magnetic programming switches, and a linear 4-20mA DC output. Magnetic program switches located on either side of the ITM are activated via a hand-held magnetic programming tool, thus allowing non-intrusive operator interface with the Transmitter Module. Electrical classifications are Class I, Div 1, Groups C, and D.

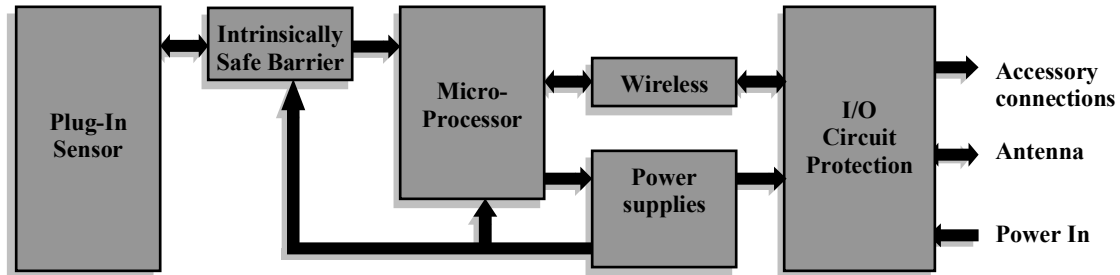

Figure 5 Functional Block Diagram

1.2.2 Field Replaceable Sensor

The Teledyne Detcon family of electrochemical gas sensor is field proven, plug-in sensors with over-sized gold-plated connections that eliminate corrosion problems. The sensor can be accessed and replaced in the field easily by releasing the locking screw and unthreading the Splashguard Adapter Assembly. Teledyne Detcon's family of toxic sensors has a long shelf life and is supported by an industry-leading warranty.



Figure 6 Plug-in Sensor

1.3 CXT Wireless Network

The CXT-DM sensor utilizes a transceiver radio, based upon the IEEE 802.15.4 standard. The transceiver operates at 2.4 GHz using DSSS encoding for robustness. DSSS was initially used by the military to resist jamming but later was widely adopted for wireless implementations since it was robust in noisy environments. DSSS transmits data across a wider frequency range than the actual frequency range required for the information. This operation minimizes cross talk and interference from other transceivers and is less susceptible to noise from other sources.

The IEEE 802.15.4 defines 16 separate RF Channels that can be used in the 2.4 GHz range. The default channel is 1 but can be changed if there is RF interference or if there is an existing network using that channel. Transceivers will only respond to other transceivers with the same RF Channel.

NOTE: If there are multiple Modbus™ networks in the same vicinity each system must reside on a different RF Channel to keep data from one appearing on the other.

The 802.15.4 standard also implements a mesh network allowing any CXT-DM transceiver to relay or repeat data between adjacent neighbors. This makes the network very robust and provides the following immediate benefits:

- Allows re-routing of data in case of loss of a transceiver
- Allows re-routing around wireless obstacles
- Longer distances between transceivers because data can “hop” from one transceiver to the next
- Included in sensor, controller and alarm station transceivers
- CXT-DM transceivers can be deployed with less concern about physical location

1.4 Battery Pack Options

The CXT-DM can be powered by an optional battery pack that enables it to be remotely mounted without the need for external cabling. Teledyne Detcon offers several battery pack options. These options are factory installed. Contact Teledyne Detcon for more information on these options.

1.4.1 Teledyne Detcon's Smart Battery Pack

The Teledyne Detcon's plug-in Smart Battery Packs provides an output of 12VDC (See Figure 7). There are two versions of the Smart Battery Pack. The first one is the 12V 2200mAh battery Pack (Teledyne Detcon's part number 976-0BP303-120) and the second is the 12V 2900mAh Battery Pack. The CXT-DM monitors the battery pack for remaining battery life. The battery packs consists of rechargeable Lithium-Ion batteries and are equipped with integrated safety electronics that include a fuel gauge, voltage monitor, and current and temperature monitoring circuits. This "smart" circuitry continuously monitors the battery's condition and reports critical status information to the wireless transceiver via the Modbus™ registers. The battery packs are designed to plug into an 8-pin Beau connector on the Terminal Board that the sensor is connected to. The battery Pack and Terminal Board are housed in Teledyne Detcon's Aluminum Condulet to protect them from exposure to outside elements and still provide Class I Div 1, C, and D approvals. Operating periods before recharge will vary based on sensor attached, but can be as long as 3.5 months for the 12V 2200mAh battery pack, and 5 months for the 12V 2900mAh battery pack before battery recharging is required. Improper use of the battery pack may be hazardous to personnel or the environment and will void the warranty.



Figure 7 Smart Battery Pack

Quad Battery Charger (Optional)

Teledyne Detcon's Smart Battery Pack can be charged as needed using Teledyne Detcon's optional Quad Battery Charger which can charge up to four battery packs at one time. The Quad Battery Charger comes with a plug-in AC/DC adapter that plugs into a standard 100-240VAC outlet for power. The DC end of the adapter plugs into the DC power jack of the charger providing 24VDC. The Quad Battery Charger has four charging ports, each with 8-pin Beau connectors for battery pack connection. The ports and connectors are keyed to prevent incorrect positioning and connection. Each port has its own "FAULT" LED indicator and "CHARGE" LED indicator and will display either a red light or green light depending on the status of each battery being charged. Charging times will vary depending on the charge state of each battery pack, but a full charge of a depleted battery pack can take up to 24 hours.



Figure 8 Quad Battery Charger

1.4.2 D Cell Lithium Battery Pack

The D Cell Lithium Battery Pack (Figure 9) contains five 3.6V Lithium Primary D size batteries which are not re-chargeable. This battery pack provides the unit with 18 volts. The batteries are contained in a battery holder mounted in Teledyne Detcon's aluminum explosion proof conduit. The CXT-DM sensors will operate up to 9 months before battery replacement is needed. The battery Pack and Terminal Board are housed in Teledyne Detcon's Aluminum Conduit to protect them from exposure to outside elements and still provide Class I Div 1, C, and D approvals.

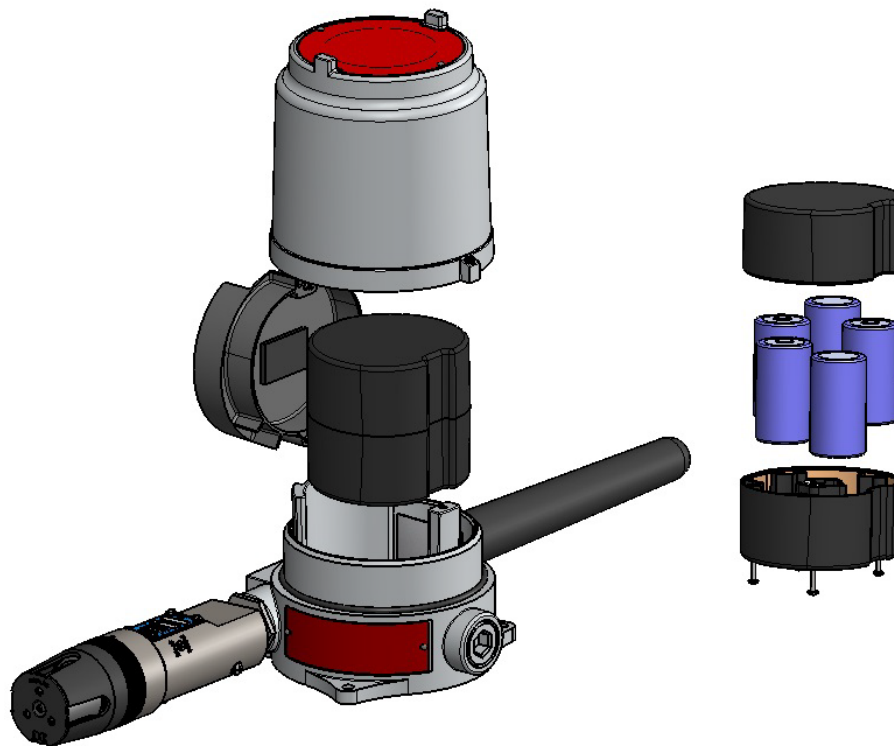

Figure 9 D-Cell Lithium Battery Pack

2. Installation

2.1 Hazardous Locations Installation Guidelines for Safe Use

NOTE: The CXT-DM assembly with strobe is not rated for Class I Division 1 or Class I Zone 1 applications. The following guidelines only apply to a CXT-DM assembly *without* a strobe.

1. Install the sensor only in areas with classifications matching the approval label. Follow all warnings listed on the label.
2. Do not remove the junction box cover while in the classified area unless it is confirmed there is no explosive gas levels in the area.
3. A good ground connection should be verified between the sensor's metal enclosure and the junction box. If a good ground connection is not made, the sensor can be grounded to the junction box using the sensor's external ground lug. Verify a good ground connection between the junction box and earth ground.
4. Proper precautions should be taken during installing and maintenance to avoid the build-up of static charge on the plastic components of the sensor (Splash Guard and Antenna Dome Cover) Wipe with damp cloth on plastic components to avoid static discharge.
5. Do not substitute components. Substitution of components may impair the intrinsic safety rating.
6. Do not operate the sensor outside of the stated operating temperature limits.
7. Do not operate the sensor outside the stated operating limits for voltage supply.
8. These sensors meet ATEX standards EN IEC 60079-0:2018, EN 60079-1:2014, EN 60079-11: 2012.
9. These sensors have a maximum safe location voltage of $U_m=30V$.
10. These sensors pass dielectric strength of 500VRMS between circuit and enclosure for a minimum of 1 minute at a maximum test current of 5mA.
11. The CXT-DM may be used as an oxygen deficiency sensor; the CXT-DM must not be used for detecting oxygen concentrations expected to be greater than 21%
12. The CXT-DM must only use gas sensor cell model 371-xxxx00-yyy. No other gas sensor shall be used.
13. The CXT-DM is only to be used with Teledyne Detcon P/N 360-026500-000 batteries (Tadiran Model TL-5920). The battery holder utilizes three of these batteries in series to operate the sensor.
14. For North American use only, the CXT-DM may use Teledyne Detcon P/N 360-TL5930-000 batteries (Tadiran Model TL-5930). The battery holder utilizes 5 of these D cell batteries in series to operate the sensor.
15. For North American use only, the CXT-DM may use Teledyne Detcon P/N 360-3S6P00-000 (2200mAh) or P/N 360-3SP00-290 (2900mAh) rechargeable Lithium batteries.
16. The CXT-DM contains FCC ID U90-RF220 and IC 7084A-RF220.
17. The CXT-DM complies with FCC Maximum Permissible Exposure (MPE) requirements when used with an approved antenna and the antenna is at least 20cm away from the user. Use of the product closer than 20cm may exceed the MPE limits. Use of any antenna other than the approved antennas will invalidate the certification of the product.
18. The CXT-DM complies with Part 15 of the FCC Rules. Operation is subject to the following two conditions: (1) This device may not cause harmful interference, and (2) this device must accept any interference received, including interference that may cause undesired operation.

WARNING: CSA certification does not include wireless communication or Modbus used for combustible gas performance. The wireless communication or Modbus may only be used for data collection or record keeping with regard to combustible gas detection. Gas indication and alarm functions for performance are only permitted locally by the detector.

2.2 Sensor Placement

Selection of sensor location is critical to the overall safe performance of the product. Six factors play an important role in selection of sensor locations:

- (1) Density of the gas to be detected
- (2) Most probable leak sources within the industrial process
- (3) Ventilation or prevailing wind conditions
- (4) Personnel exposure
- (5) Placement of transmitting antenna
- (6) Maintenance access

Density

Placement of sensors relative to the density of the target gas is such that sensors for the detection of heavier than air gases should be located within 4 feet of grade as these heavy gases will tend to settle in low lying areas. For gases lighter than air, sensor placement should be 4-8 feet above grade in open areas or in pitched areas of enclosed spaces.

Leak Sources

The most probable leak sources within an industrial process include flanges, valves, and tubing connections of the sealed type where seals may either fail or wear. Other leak sources are best determined by facility engineers with experience in similar processes.

Ventilation

Normal ventilation or prevailing wind conditions can dictate efficient location of gas sensors in a manner where the migration of gas clouds is quickly detected.

Personnel Exposure

The undetected migration of gas clouds should not be allowed to approach concentrated personnel areas such as control rooms, maintenance or warehouse buildings. A more general and applicable thought toward selecting sensor location is combining leak source and perimeter protection in the best possible configuration.

Maintenance Access

Consideration should be given to providing easy access for maintenance personnel. Consideration should also be given to the consequences of close proximity to contaminants that may foul the sensor prematurely.

NOTE: In all installations the gas sensor should point straight down (refer to Figure 12). Improper sensor orientation may result in false readings and permanent sensor damage.

Placement of RF Antenna

Placement of the sensor should also have consideration made for line of sight RF Transmissions. The devices should be placed in a reasonable proximity to other devices in the network. Obstacles between CXT transceivers can impact RF line-of-sight and may result in communication problems. The CXT sensor should be in view of at least one other transceiver.

Additional Placement Considerations

The sensor should not be positioned where it may be sprayed or coated with surface contaminating substances. Painting sensor assemblies is prohibited.

Although the sensor is designed to be RFI resistant, it should not be mounted in close proximity to high-powered radio transmitters or similar RFI generating equipment.

When possible mount in an area void of high wind, accumulating dust, rain, or splashing from hose spray, direct steam releases, and continuous vibration. If the sensor cannot be mounted away from these conditions then make sure the Teledyne Detcon Harsh Location Dust Guard accessory is used.

Do not mount in locations where temperatures will exceed the operating temperature limits of the sensor. Where direct sunlight leads to exceeding the high temperature-operating limit, use a sunshade to help reduce temperature.

2.3 Sensor Contaminants and Interference

Electrochemical toxic gas may be adversely affected by exposure to other airborne gases. Depending on the cross-sensitivity relationship, there may be a positive or negative impact on the reading.

The most commonly present gases that potentially cause interference problems are listed in Table 4 Interfering Gases and Table 5 Cross Interference Table (Refer to section 9.3 Interference Table).

The presence of cross-interference gases in an area does not preclude the use of this sensor technology, although it is possible that the sensor could experience a false high or false low reading should exposure occur.

Cross-Interference Data Table

Table 5 Cross Interference Table (refer to Section 9.3 Interference Table) lists the gases typically found in industrial environments that may cause a cross-interference response on members of the Teledyne Detcon family of toxic gas sensors. Review Table 5 in Section 9.3. for the correct gas and then scan across the list for possible interference gases. Determine the magnitude of cross-interference that may occur.

2.4 Sensor Mounting

The CXT-DM should be vertically oriented so that the sensor points straight downward. The explosion-proof enclosure or junction box is typically mounted on a wall or pole (See Figure 12). Teledyne Detcon provides a selection of standard junction boxes in both Aluminum and Stainless Steel.

NOTE: If wall mounting without a mounting plate, make sure to use at least 0.5" spacers underneath the Teledyne Detcon Aluminum Junction-Box's 1/4" mounting holes to move the sensor assembly away from the wall and allow access clearance to the sensor assembly.

NOTE: Do not use Teflon Tape or any other type of Pipe Thread material on the 3/4" threads unless the sensor is mounted in a severe or harsh environment. Metal-on-metal contact must be maintained to provide a solid electrical ground path. If Teflon Tape is used the Sensor *must* be externally grounded using a ground strap.

When mounting on a pole, secure the Junction Box to a suitable mounting plate and attach the mounting plate to the pole using U-Bolts. (Pole-Mounting brackets for Teledyne Detcon Junction Boxes are available separately.)

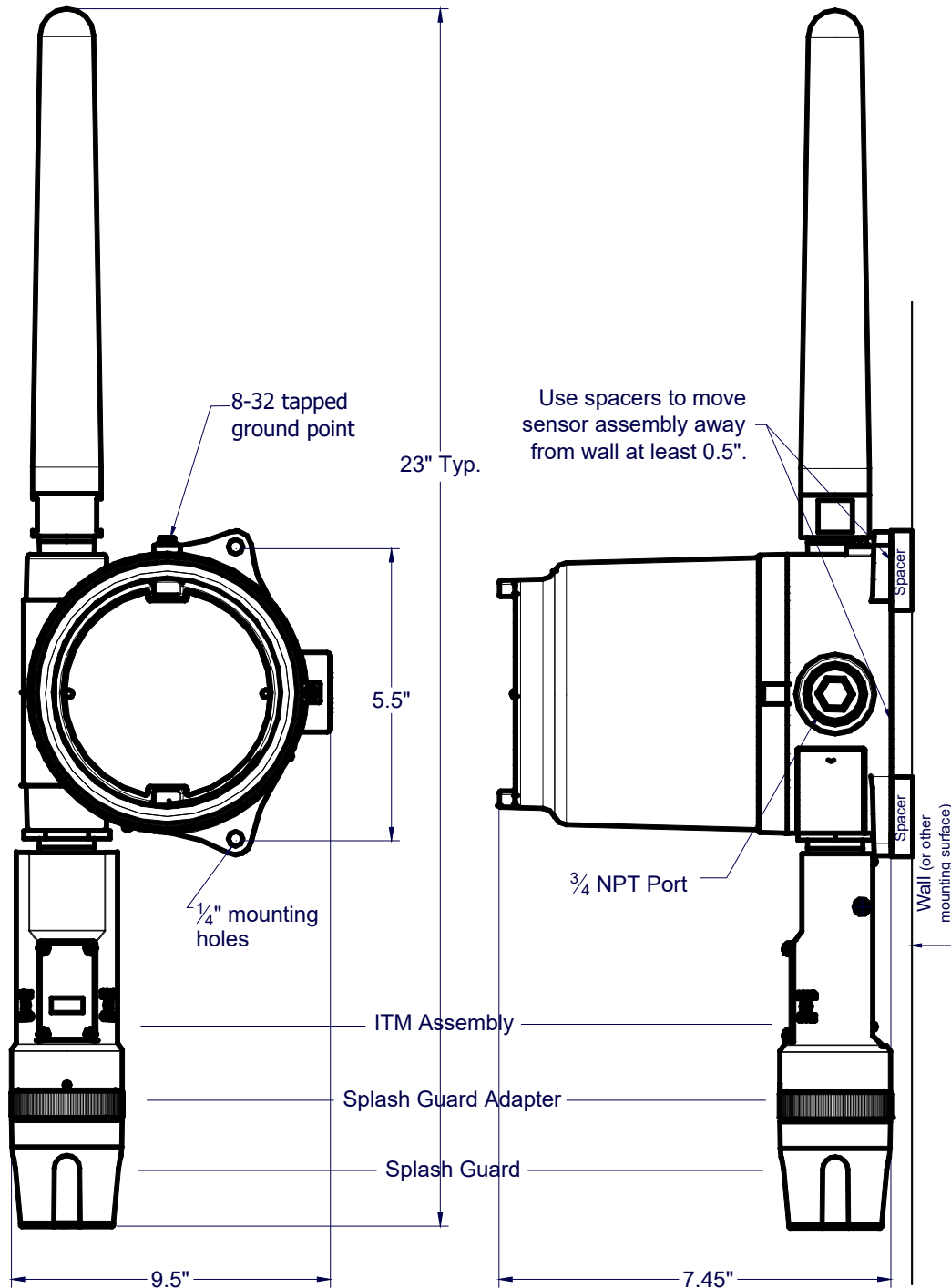

Figure 10 CXT-DM Sensor with D or Smart Battery Pack Mounting Dimensions

2.5 Electrical Installation

The CXT is designed to be battery operated, and normally will not have external cabling or wiring. If the sensor requires external wiring, the Sensor Assembly should be installed in accordance with local electrical codes. Proper electrical installation of the gas sensor is critical for conformance to electrical codes and to avoid damage due to water leakage.

If a conduit run exists a drain should be incorporated. The drain allows H₂O condensation inside the conduit run to safely drain away from the sensor assembly. The electrical seal fitting is required to meet the National Electrical Code per NEC Article 500-3d (or Canadian Electrical Code Handbook Part 1 Section 18-154). Requirements for locations of electrical seals are covered under NEC Article 501-5. Electrical seals also act as a secondary seal to prevent water from entering the wiring terminal enclosure. However, they are not designed to provide an absolute watertight seal, especially when used in the vertical orientation.

NOTE: The Teledyne Detcon Warranty does not cover water damage resulting from water leaking into the enclosure.

NOTE: Any unused ports should be blocked with suitable $\frac{3}{4}$ " male NPT plugs. Teledyne Detcon supplies one $\frac{3}{4}$ " NPT male plug with each J-box enclosure. If connections are other than $\frac{3}{4}$ " NPT, use an appropriate male plug of like construction material.



CAUTION: Do not apply power to the sensor until all wiring is properly terminated (See section 2.6, Initial Start Up).

2.5.1 Applying Power to the Unit



CAUTION: A 24V solar panel is the most common option for supplying external power. A solar panel will recharge the Teledyne Detcon Smart Battery Pack. **DO NOT CHARGE IN A HAZARDOUS LOCATION.** It CANNOT be used with the C-cells or D-cells. A 24V input with the C-cells or D-cells will damage the cells.

1. Remove the junction box cover
2. If external power is to be applied to the unit, connect the incoming 24V to the Connector labeled 'DC INPUT'. Connect 24V to the terminal labeled '24VDC' and Return to the terminal labeled "GND". The Battery Bracket will need to be removed in order to access the connector.
3. Install the batteries:

NOTE: The safety approvals require removing entire sensor assembly to a non-hazardous area before installing or changing out the batteries or battery pack.

- a) For units utilizing the 12V Smart Battery Pack or the D-Size Battery Holder/pack, remove the battery cover by unscrewing the top screws and moving the battery cover out of the way. Plug the battery pack into the Terminal Board. Power will be applied, and the unit will proceed to power up (Section 2.6). The battery Packs will only plug in in one orientation. Replace the Battery Cover and tighten the two screws down to secure the battery pack in place.
- b) If the unit utilizes the "C" sized lithium 3.6V batteries and battery holder, install the batteries being careful to install the batteries properly. Power will be applied, and the unit will proceed to power up (Section 2.6).

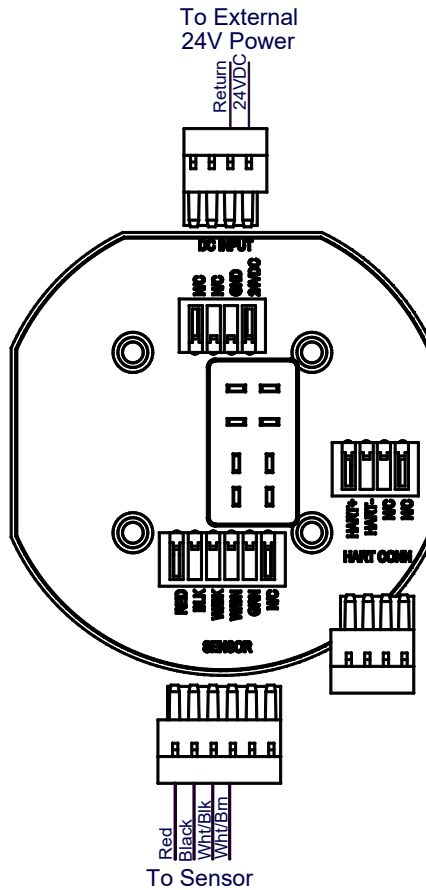

Figure 11 Terminal Interconnect for Smart Battery Pack

4. Replace the junction box cover after Initial Start Up. Ensure that the cover is screwed down completely and that the Allen Head screw is tightened down to secure the cover in place.

NOTE: A 6-32 or 8-32 threaded exterior ground point is provided on most junction boxes for an external ground. If the Sensor Assembly is not mechanically grounded, an external ground strap *must* be used to ensure that the sensor is electrically grounded.

2.6 Initial Start Up

2.6.1 Toxic Gas Sensors

Upon completion of all mechanical mounting, install the batteries; this will apply power to the unit. If the unit is equipped with the optional power switch, power is applied by pushing the switch. Observe the following normal conditions:

1. Upon power up the sensor will scroll “CXT-DM V##.##” and will then display the current reading for about 5 seconds. A temporary upscale reading may occur as the sensor stabilizes. This upscale reading will decrease to “0” ppm within 1-2 minutes of power-up, assuming there is no gas in the area of the sensor. Sensors cells that use a bias voltage require a longer time to stabilize. This can vary between 1 and 24 hours depending on the sensor type and range. Biased sensors include NO, HCl, and VOC gases (ethylene oxide, ethylene, methanol, formaldehyde . . . etc.)
2. After the initial power up the sensor display will turn off. Thereafter the display will come on once every 10 seconds and will display the current reading for about 2 seconds, and will return to a blank display to conserve battery power.

NOTE: In normal operation the display will come on once every 10 seconds, will display the current reading for about 2 seconds, and will return to a blank display to conserve battery power.

Initial Operational Tests

After a warm up period of 1 hour (or when zero has stabilized), the sensor should be checked to verify sensitivity to the target gas.

Material Requirements

- Teledyne Detcon PN 613-120000-700 700 Series Splash Guard with integral Cal Port and Calibration Wind Guard (P/N 943-000000-000) -OR-
- Teledyne Detcon PN 943-000006-132 Threaded Calibration Adapter - OR -
- Teledyne Detcon P/N 943-01747-T05 Teflon Calibration Adapter for highly reactive gases
- Teledyne Detcon Span Gas; 50% of range target gas in balance N₂ or Air at fixed flow rate between 200-500cc/min

NOTE: Calibration gas generators using perm tubes or electrochemical sources may be used in place of span gas cylinders.

NOTE: Wind Guard must be used when calibrating with the integral cal port to ensure proper calibration.

1. Attach the calibration adapter to the Splashguard Adapter Assembly or connect tubing to integral cal port. It is recommended that the Wind Guard (Teledyne Detcon P/N 943-000000-000) is installed over the Splash Guard during calibration. Apply the test gas at a controlled flow rate of 200 - 500cc/min (500cc/min is the recommended flow). Observe that the ITM display increases to a level near that of the applied calibration gas value.
2. Remove test gas and observe that the display decreases to “0”.
3. If a calibration adapter was used during these tests, remove them from the unit, and re-install the Splash Guard. If the wind guard was used, remove the wind guard.

Initial operational tests are complete. CXT-DM toxic gas sensors are factory calibrated prior to shipment, and should not require significant adjustment on start up. However, it is recommended that a complete calibration test and adjustment be performed 16 to 24 hours after power-up. Refer to zero and span calibration instructions in Section 3.3.

2.6.2 O₂ Deficiency Sensors

- a) When first powered up the CXT-DM display should read close to 20.9%.
- b) The reading should stabilize within 1 to 2 minutes of power-up (assuming a ‘normal’ ambient O₂ concentration).

Initial Operational Tests

After a warm-up period of 5 minutes the sensor should be checked to verify response to O₂ deficiency.

Material Requirements

- Teledyne Detcon PN 613-120000-700 700 Series Splash Guard with integral Cal Port and with Wind Guard -OR-
 - Teledyne Detcon PN 943-000006-132 Threaded Calibration Adapter
 - Teledyne Detcon Zero Gas: 100% N₂ at fixed flow rate of 200-500cc/min
- a) Attach the calibration adapter to the threaded sensor housing or connect tubing to the integral cal port. Apply the test gas at a controlled flow rate of 200-500cc/min (500cc/min is the recommended flow). Observe that the ITM display decreases to a level near zero.

NOTE: Wind Guard must be used when calibrating with the integral cal port to ensure proper calibration.

- b) Remove test gas and calibration adapter. The ITM display should return to a reading of 20.9%.

Initial operational tests are complete. CXT-DM O₂ deficiency sensors are factory calibrated prior to shipment, and should not require significant adjustment on start up. However, it is recommended that a complete calibration test and adjustment be performed 16 to 24 hours after power-up. Refer to zero and span calibration instructions in Section 3.3.

3. Operation

The Operator Interface of the Model CXT Series gas sensors is accomplished via two internal magnetic switches located to either side of the LED display (see Figure 16). The two switches, labeled “PGM1” and “PGM2”, allow for complete calibration and configuration, thereby eliminating the need for area de-classification or the use of hot permits.



Figure 12 Magnetic Programming Tool

The magnetic programming tool (Figure 15) is used to operate the magnetic switches. Switch action is defined as momentary contact (a swipe), a 3-second hold, and a 10-second hold. (Hold times are defined as the time from the point when the arrow-prompt “↔” appears. Swiping the magnet does not display the “↔” prompt.) For momentary contact use, the programming magnet is briefly held over a switch location, or swiped. For 3-second hold, the programming magnet is held in place over the switch location for three seconds. For 10-second hold, the programming magnet is held in place over the switch location for 10 seconds. The 3 and 10 second holds are generally used to enter calibration/program menus and save new data. The momentary contact is generally used to move between menu items and to modify set-point values. Arrows (“↔” and “↔”) are used on the LED display to indicate when the magnetic switches are activated. The location of “PGM1” and “PGM2” are shown in Figure 16.

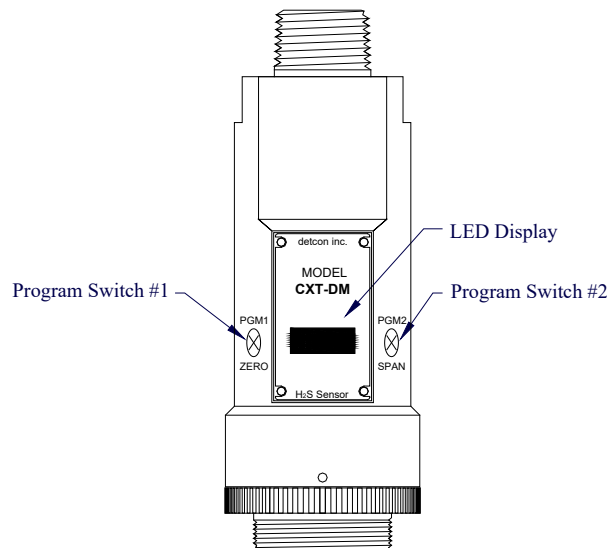

Figure 13 Magnetic Programming Switches

NOTE: While in the Program Mode, if there is no magnetic switch interaction after 4 consecutive menu scrolls, the sensor will automatically revert to normal operating condition. While changing values inside menu items, **if there is no magnet activity after 3-4 seconds the sensor will revert to the menu scroll.** If the sensor is in Bump Test mode, the display will remain active.

3.1 Operator Interface

The operating interface is menu-driven via the two magnetic program switches located under the target marks of the sensor housing. The two switches are referred to as “PGM1” and “PGM2”. The menu list consists of three menu items that include sub-menus:

Normal Operation

Concentration Reading is displayed once every 10 seconds.

Calibration Mode

AutoZero

AutoSpan

Program Mode

View Sensor Status

Mp App ##.##

CP App ##.##

Rf App ##.##.##

Rf Sw ##.##

Modbus ID ##

Serial Number ##.##.##

RF Channel ##

Network ID #####

Range ###

Autospan Level ##

Tempcomp Level ##

Last Cal ## Days

Sensor Life ###%

Temperature ##C

Alarm 1

Alarm 2

Set Detection Range

Set Autospan Level

Bump Test

Restore Defaults

Set RF Channel

Alarm Settings

Set Modbus ID

Software Flowchart

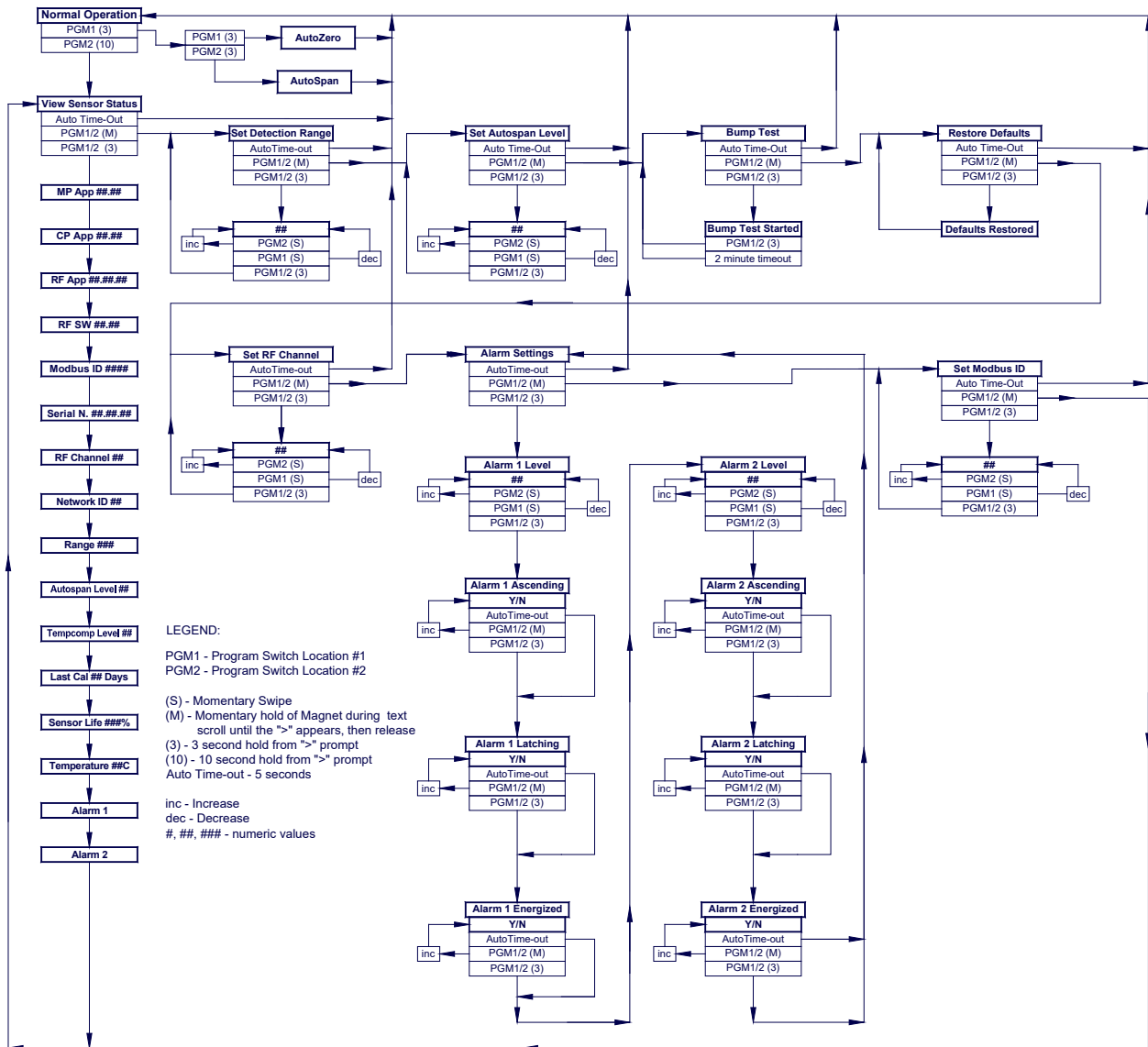



Figure 14 Menu Flow Chart

3.2 Normal Operation

In normal operation, the ITM Display will be blank and will display the gas reading once every 10 seconds for about 2 seconds (normally appear as “0”). At any time swiping a magnet across either PGM1 or PGM2 will cause the ITM to display the range and gas type (i.e. “ppm H2S”). If the sensor is actively experiencing any diagnostic faults, a swipe of the magnet will cause the display to scroll the fault condition. Refer to Section 5 Service and Maintenance for more information on fault conditions.

3.3 Calibration Mode

Zero and span calibration should be performed on a routine basis (quarterly minimum is advised) to ensure reliable performance. If a sensor has been exposed to any de-sensitizing gases, or to very high over-range combustible gas levels, re-calibration should be considered. Unless otherwise specified, span adjustment is recommended at 50% of the full scale range.

To enter Calibration Mode hold the magnet over PGM1 for 3 seconds. If the sensor is experiencing a fault condition the “” prompt will not appear until the fault(s) have been displayed. When the ITM enters Calibration Mode the display will scroll “Pgm1=Zero . . . Pgm2=Span” twice before returning to Normal Mode (about 5 seconds).

3.3.1 AutoZero

The AutoZero function is used to zero the sensor. AutoZero should be performed periodically or as required. AutoZero should be considered after periods of over-range target gas exposure. Local ambient air can be used to zero calibrate a toxic gas sensor as long as it can be confirmed that it contains no target or interference gasses. If this cannot be confirmed then a zero air or N₂ cylinder should be used. Pure N₂ must be used for zero calibration of the O₂ deficiency sensors.

Material Requirements:

- Teledyne Detcon PN 327-000000-000 MicroSafe™ Programming Magnet
- Teledyne Detcon PN 613-120000-700 Splash Guard with integral Cal Port and with Wind Guard. -OR-
- Teledyne Detcon PN 943-000006-132 Threaded Calibration Adapter
- Teledyne Detcon PN 942-001123-000 Zero Air cal gas (or use ambient air if no target gas is present).
- Teledyne Detcon P/N 942-640023-100 Nitrogen 99.99%

NOTE: The zero gas source may be zero air or N₂ for toxic sensors, but must be pure N₂ (99.99%) for O₂ deficiency sensors .

NOTE: The Calibration Wind Guard must be used when the Splashguard Adapter with integral Cal Port is used. Failure to use the Calibration Wind Guard may result in an inaccurate AutoZero calibration.

- a) For toxic sensors, if the ambient air is known to contain no target gas content, then it can be used for zero calibration. If a zero gas cal cylinder is going to be used, attach the calibration adapter and set flow rate of 200-500cc/min (500cc/min is the recommended flow rate) and let sensor purge for 1-2 minutes before executing the AutoZero. For O₂ deficiency sensors, apply N₂ at a set flow rate of 500cc/min for 3-5 minutes before executing AutoZero.
- b) From Normal Operation, enter Calibration Mode by holding the programming magnet over PGM1 for 3 seconds. Note, the “◆” prompt will show that the magnetic switch is activated during the 3 second hold period. The display will then scroll “Pgm1=Zero . . . Pgm2=Span”. Hold the programming magnet over PGM1 for 3 seconds once the “◆” prompt appears to execute AutoZero (or allow to timeout in 5 seconds if AutoZero is not desired).

NOTE: Upon entering Calibration Mode, the Modbus™ Status Register bit 14 is set to signify the sensor is in-calibration mode. This bit will remain set until the program returns to normal operation.

- c) The ITM will display the following sequence of text messages as it proceeds through the AutoZero sequence:

Zero Cal . . . Setting Zero . . . Zero Saved (each will scroll twice)

- d) Remove the zero gas and calibration adapter, if applicable.

3.3.2 AutoSpan

The AutoSpan function is used to span calibrate the sensor. AutoSpan should be performed periodically or as required. AutoSpan should be considered after periods of over-range target gas exposure. Unless otherwise specified, span adjustment is recommended at 50% of range. This function is called “AUTO SPAN”.

NOTE: Before performing AutoSpan Calibration, verify that the AutoSpan level matches the span calibration gas concentration as described in Section 3.4.4.

Material Requirements:

- Teledyne Detcon PN 327-000000-000 MicroSafe™ Programming Magnet
- Teledyne Detcon Splash Guard with integral Cal Port (PN 613-120000-700) and Calibration Wind Guard (PN 613-120000-700) -OR-
- Teledyne Detcon PN 943-000006-132 Threaded Calibration Adapter
- Teledyne Detcon Span Gas (See Teledyne Detcon for Ordering Information). Recommended span gas is 50% of range with target gas. Other suitable span gas sources containing the target gas in air or N₂ balance are acceptable.

NOTE 1: Contact Teledyne Detcon for Ordering Information on Span Gas cylinders.

NOTE 2: A target gas concentration of 50% of range is strongly recommended. This should be supplied at a controlled flow rate of 200 to 500cc/min, with 500cc/min being the recommended flow rate. Other concentrations can be used if they fall within allowable levels of 5% to 100% of range.

NOTE 3: The Calibration Wind Guard must be used when the Splashguard Adapter with integral Cal Port is used. Failure to use the Calibration Wind Guard may result in an inaccurate AutoZero calibration.

NOTE 4: Ambient air should be used to calibrate O₂ deficiency sensors as long as the oxygen concentration is confirmed to be 20.9%.

NOTE 5: It is generally not advised to use other gasses to cross-calibrate for span. Cross-calibration by use of other gasses should be confirmed by Teledyne Detcon.



CAUTION: Verification that the calibration gas level setting matches the calibration span gas concentration is required before executing “AutoSpan” calibration. These two numbers must be equal.

AutoSpan consists of entering Calibration Mode and following the menu-displayed instructions. The display will ask for the application of span gas in a specific concentration. The applied gas concentration must be equal to the calibration gas level setting. The factory default setting and recommendation for span gas concentration is 50% of range. If a span gas containing the recommended concentration is not available, other concentrations may be used as long as they fall between 5% and 100% of range. However, any alternate span gas concentration value must be programmed via the “**Set AutoSpan Level**” menu before proceeding with AutoSpan calibration. Follow the instructions “a” through “e” below for AutoSpan calibration.

- a) Verify that the AutoSpan Level is equal to the Calibration Span Gas Concentration. (Refer to View Sensor Status in Section 3.4.2.) If the AutoSpan Level is not equal to the Calibration span gas concentration, adjust the AutoSpan Level as instructed in Section 3.3.2.
- b) From Normal Operation, enter Calibration Mode by holding the programming magnet over PGM1 for 3 seconds. Note, the “**▶**” prompt will show that the magnetic switch is activated during the 3 second hold period. The display will then scroll “**PGM1=Zero PGM2=Span**”. Hold the programming magnet over PGM2 for 3 seconds to execute AutoSpan (or allow to timeout in 5 seconds if AutoSpan is not intended). The ITM will then scroll “**Apply XX ppm Gas**”.

NOTE: Upon entering Calibration Mode, the Modbus™ Status Register bit 14 is set to signify the sensor is in-calibration mode. This bit will remain set until the program returns to normal operation.

- c) Apply the span calibration test gas for toxic gas sensors at a flow rate of 200-500cc/min (500cc/min is the recommended flow rate). As the sensor signal begins to increase the display will switch to flashing “**XX**” reading as the ITM shows the sensor’s “as found” response to the span gas presented. If it fails to meet the minimum in-range signal change criteria within 2 minutes, the display will report “**Range Fault**” twice and the ITM will return to normal operation, aborting the AutoSpan sequence. The ITM will continue to report a “Range Fault” for 1 minute.

NOTE: Ambient air should be used to calibrate O₂ deficiency sensors as long as the oxygen concentration is confirmed to be 20.9%. There is no need to apply a flow of gas.

Assuming acceptable sensor signal change, after 1 minute the reading will auto-adjust to the programmed AutoSpan level. The ITM then reports the following messages:

“**Remove Gas**”

- d) Remove the span gas source and calibration adapter. The ITM will report a live reading as it clears toward “0”. When the reading clears below 10% of range, the ITM will display “**Span Complete**” and will revert to normal operation. If the sensor fails to clear to less than 10% in less than 5 minutes, a “**Clearing Fault**” will be reported twice and the ITM will return to normal operation, aborting the AutoSpan sequence. The ITM will continue to report a “**Clearing Fault**” for 1 minute.

NOTE: When calibrating O₂ deficiency sensors, there is no requirement to clear to <5% of range. The sensor will return to normal operation immediately after span adjustment.

e) AutoSpan calibration is complete.

NOTE 1: If the sensor fails the minimum signal change criteria, a “**Range Fault**” will be declared and the ‘Range Fault’ fault bit will be set on the Modbus™ output.

NOTE 2: If the sensor fails the clearing time criteria, a “**Clearing Fault**” will be declared and the ‘Clearing Fault’ fault bit will be set on the Modbus™ output.

3.4 Program Mode

Program Mode provides a “**View Sensor Status**” menu to check operational and configuration parameters. Program Mode provides for adjustment of the detection range, AutoSpan Level, RF Channel, and Modbus ID. Additionally, Program Mode includes the diagnostic function “Bump Test” and “Restore Defaults”.

The Program Mode menu items appear in the order presented below:

- View Sensor Status
- Set Detection Range
- Set Autospan Level
- Bump Test
- Restore Defaults
- Set RF Channel
- Alarm Settings
- Set Modbus ID

3.4.1 Navigation Program Mode

From Normal Operation, enter Program Mode by holding the magnet over PGM2 for 3 seconds. Note, the “**▶**” prompt will show that the magnetic switch is activated during the 3 second hold period. If the sensor is experiencing a fault condition the “**▶**” prompt will not appear until the fault(s) have been displayed. The ITM will enter Program Mode and the display will display the first menu item “**View Sensor Status**”. To advance to the next menu item, hold the magnet over PGM1 or PGM2 while the current menu item’s text is scrolling. At the conclusion of the text scroll the arrow prompt (“**▶**” for PGM2 or “**◀**” for PGM1) will appear, and immediately remove the magnet. The ITM will advance to the next menu item. Repeat this process until the desired menu item is displayed. Note, PGM1 moves the menu items from right to left and PGM2 moves the menu items from left to right.

To enter a menu item, hold the magnet over PGM1 or PGM2 while the menu item is scrolling. At the conclusion of the text scroll the “**▶**” prompt (“**▶**” for PGM2 or “**◀**” for PGM1) will appear, continue to hold the magnet over PGM1 or PGM2 for an additional 3-4 seconds to enter the selected menu item. If there is no magnet activity while the menu item text is scrolling (typically 4 repeated text scrolls), the ITM will automatically revert to Normal Operation.

3.4.2 View Sensor Status

View Sensor Status displays all current configuration and operational parameters including: sensor type, software version number, gas type, detection range, AutoSpan level, days since last AutoSpan, estimated remaining sensor life, raw sensor current, mA output, input voltage and sensor ambient temperature.

From the **View Sensor Status** text scroll, hold the magnet over PGM1 or PGM2 until the “**▶**” prompt appears and continue to hold the magnet in place for an additional 3-4 seconds (until the display starts to scroll “**Status Is**”). The display will scroll the complete list of sensor status parameters sequentially:

Main processor firmware version

The menu item appears as: “**Mp App ##.##**”

Co-processor firmware version

The menu item appears as: “**Cp App ##.##**”

Rf firmware version

The menu item appears as: “**Rf App ##.##.##**”

Rf Software version

The menu item appears as: “**Rf Sw ##.##**”

Modbus ID

The menu item appears as: “**Modbus ID is ##**”

Serial Number

The menu item appears as: “**Serial Number ##.##.##**”.

This is the serial number for the radio embedded in the CXT-DM.

RF Channel

The menu item appears as: “**RF Channel ##**”

Network ID

The menu item appears as: “**Network ID #####**”

Range

The menu item appears as: “**Range ###**”

AutoSpan Level

The menu item appears as: “**Auto Span Level ##**”

Temperature Compensation Level

The menu item appears as: “**Tempcomp Level ##**”

Last Cal

The menu item appears as: “**Last Cal ## Days**”

Sensor Life

The menu item appears as: “**Sensor Life ###%**”

Temperature

The menu item appears as: “**Temperature ##C**”

Alarm1

The menu item appears as: “**Alarm1 Level ##**”

“**Ascending**” or “**Decending**”

“**Latching**” or “**NonLatching**”

“**Energized**” or “**DeEnergized**”

Alarm2

The menu item appears as: “**Alarm2 Level ##**”

“**Ascending**” or “**Decending**”

“**Latching**” or “**NonLatching**”

“**Energized**” or “**DeEnergized**”

When the status list sequence is complete, the ITM will revert to the “View Sensor Status” text scroll. The user can either:

- 1) Review list again by executing another 3-4 second hold,
- 2) Move to another menu item by executing a momentary hold over PGM1 or PGM2, or
- 3) Return to Normal Operation via automatic timeout of about 15 seconds (the display will scroll “View Sensor Status” 4 times and then return to Normal Operation).

3.4.3 Set Detection Range

The full-scale range of a CXT-DM sensor is determined at the time of order. The Plug-in Sensor is factory calibrated for this range. The range should not be changed in the field unless directed to do so by Teledyne Detcon.

NOTE: The sensor range should not be changed in the field unless directed to do so by Teledyne Detcon.

3.4.4 Set AutoSpan Level

Set AutoSpan Level is used to set the span gas concentration level that is being used to calibrate the sensor. This level is adjustable from 1% to approximately 75% or 95% dependent on full-scale range. The current setting can be viewed in View Program Status.

The menu item appears as: “**Set AutoSpan Level**”

From the **Set AutoSpan Level** text scroll, hold the magnet over PGM1 or PGM2 until the “**▶**” prompt appears and continue to hold the magnet in place for an additional 3-4 seconds (until the display starts to scroll “**Set Level**”). The display will switch to “XX“(where XX is the current gas level). Swipe the magnet momentarily over PGM2 to increase or PGM1 to decrease the AutoSpan Level until the correct level is displayed. When the

correct level is achieved, hold the magnet over PGM2 for 3-4 seconds to accept the new value. The display will scroll “**Level Saved**”, and revert to “**Set AutoSpan Level**” text scroll.

Move to another menu item by executing a momentary hold, or return to Normal Operation via automatic timeout of about 15 seconds (the display will scroll “Set AutoSpan Level” 4 times and then return to Normal Operation).

3.4.5 Bump Test

Bump Test is used to check the response of the sensor with the indication of response limited to the display only. The **Bump Test** mode allows the performance of the sensor to be checked without firing the alarms of any attached control systems. The results of the bump test will not affect the reading register on the Modbus™ output.

The menu item appears as: “**Bump Test**”

From the **Bump Test** text scroll, hold the magnet over PGM1 or PGM2 until the “**▶**” prompt appears and continue to hold the magnet in place for an additional 3-4 seconds (until the display starts to scroll “**Bump Test Started**”).

Apply span gas to the sensor according to Section 2.6.1. The Sensor will respond to the gas to test the sensor response, but the Modbus current gas reading (Modbus register 0002) will remain unchanged. Remove the gas before the ‘Bump Test’ time expires (2 minutes).

The display will return to normal operation and alternate between the live gas reading, and showing “**Bump**” until 2 minutes expires, or the execution of a momentary hold over PGM1 or PGM2, when the display will scroll “**Bump Test Ended**”.

3.4.6 Restore Defaults

Restore Factory Defaults is used to clear current user configuration and calibration data from memory and revert to factory default values. This may be required if the settings have been configured improperly and a known reference point needs to be re-established to correct the problem.

This menu item appears as: “**Restore Defaults**”.

NOTE: Restoring factory defaults should only be used when absolutely necessary. All previously existing configuration inputs will have to be re-entered if this function is executed. A full 10-second magnet hold on PGM 2 is required to execute this function.

From the “**Restore Defaults**” text scroll, hold the programming magnet over PGM2 until the “**▶**” prompt appears and continue to hold for 3-4 seconds. The display will scroll “**Defaults Restored**”, and revert to “**Restore Defaults**” text scroll.

Move to another menu item by executing a momentary hold, or, return to Normal Operation via automatic timeout of about 15 seconds (the display will scroll “**Restore Defaults**” 4 times and then return to Normal Operation).

Following the execution of “**Restore Defaults**”, the CXT-DM will revert to its factory default settings. The default settings are:

NOTE: The following must be performed in order before the sensor can be placed in operation.

- RF Channel = 4. The RF Channel should be set appropriately by the operator (Section 3.4.7).
- Modbus ID = 01. The Modbus ID must be set appropriately by the operator (Section 3.4.9).
- AutoSpan Level = 50% of range. AutoSpan level must be set appropriately by the operator (Section 3.4.4).
- Range: Defaults to range of intelligent plug-in sensor, must be set to the appropriate level by the operator (Section 3.4.3).
- AutoZero: AutoZero Settings are lost and user must perform new AutoZero (Section 3.3.2).
- AutoSpan: AutoSpan Settings are lost and user must perform new AutoSpan (Section 3.3.2).

3.4.7 Set RF Channel

Set RF Channel is used to set the RF Channel used for communication. There are 16 possible RF channels. All of the sensors must be on the same RF Channel for the network to operate properly. The RF Channel is settable from 0 to 15. The current RF Channel can be viewed in View Sensor Status.

The menu item appears as: “**Set RF Channel**”.

From the “**Set RF Channel**” text scroll, hold the programming magnet over PGM1 or PGM2 until the “**▶**” prompt appears and continue to hold the magnet in place for an additional 3-4 seconds (until the display starts to scroll “**Set Channel**”). The display will then switch to “**XX**” (where XX is the current RF Channel). Swipe the magnet momentarily over PGM2 to increase or PGM1 to decrease the hexadecimal number until the desired ID is displayed. Hold the magnet over PGM2 for 3-4 seconds to accept the new value. The display will scroll “**Channel Saved**”, and revert to “**Set RF Channel**” text scroll.

Move to another menu item by executing a momentary hold, or, return to Normal Operation via automatic timeout of about 15 seconds (the display will scroll “**Set RF Channel**” 5 times and then return to Normal Operation).

3.4.8 Alarm Settings

The Alarm Settings are not used during normal operation of the unit at this time. These settings should be ignored and bypassed.

The menu item appears as: “**Alarm Settings**”. At the conclusion of the text scroll the “**▶**” prompt (“**▶**” for PGM2 or “**◀**” for PGM1) will appear, continue to hold the magnet over PGM1 or PGM2 for an additional 3-4 seconds to move to either the next or prior menu selection. If there is no magnet activity while the menu item text is scrolling (typically 4 repeated text scrolls), the ITM will automatically revert to Normal Operation.

3.4.9 Set Modbus ID

Teledyne Detcon CXT sensor can be polled serially via Modbus™ RTU. Refer to Section 4.0 for details on using the Modbus™ output feature.

Set Modbus ID is used to set the Modbus™ address of the unit. It is adjustable from 01 to 256 in hexadecimal format (01-FF hex). Each sensor must have a unique Modbus address to operate correctly on the network. The current serial ID can be viewed in View Sensor Status.

The menu item appears as: “**Set Serial ID**”.

From the “**Set Modbus ID**” text scroll, hold the programming magnet over PGM1 or PGM2 until the “**▶**” prompt appears and continue to hold the magnet in place for an additional 3-4 seconds (until the display starts to scroll “**Set ID**”). The display will then switch to “**XX**” (where XX is the current ID address). Swipe the magnet momentarily over PGM2 to increase or PGM1 to decrease the hexadecimal number until the desired ID is displayed. Hold the magnet over PGM2 for 3-4 seconds to accept the new value. The display will scroll “**ID Saved**”, and revert to “**Set Modbus ID**” text scroll.

Move to another menu item by executing a momentary hold, or, return to Normal Operation via automatic timeout of about 15 seconds (the display will scroll “**Set Serial ID**” 5 times and then return to Normal Operation).

3.5 Fault Diagnostic/Failsafe Feature

If the ITM should incur a fault, the Global Fault bit will be set on the Modbus™ output. This can occur if the ITM detects a problem with the sensor, detects that there is no sensor connected, if the ITM has an internal fault, or other fault condition. The Global Fault bit will be set on the Modbus™ output until the problem is resolved. The display will show the Fault when a magnetic programming tool is swiped across either PGM1 or PGM2. The error codes are defined in Section 6.

4. Modbus™ Communications

Modbus™ communication with a CXT Sensor is normally accomplished using another wireless transceiver such as the RXT-320 which is connected through a RS-485 interface to a Modbus™ master control unit. The control unit can then access the Modbus™ registers within the CXT Sensor to obtain readings and status of the sensor.

As with normal Modbus™ operation, there can be only one Modbus™ master that polls all the other devices on the network which are considered Modbus™ slaves. Each sensor must have a unique Modbus™ address to work properly on the wireless network. Also each device on the wireless network must be on the same RF channel to communicate with one another. Both the Modbus ID and the RF Channel are set on the CXT Sensor using the display.

The Modbus™ master control unit with RXT-320 transceiver (or equivalent) is responsible for broadcasting requests and receiving slave device responses. The CXT Sensor receives these requests through its own internal transceiver and responds if the Modbus™ address and proper register set matches. The response will be received by the RXT-320 and presented to the master control unit across the RS-485 interface.

4.1 General Modbus™ Description

The Modbus™ communication uses the RTU transmission mode per the Modbus™ specification. The basic frame format for Modbus™ consists of a Modbus™ address, function code, data and CRC.

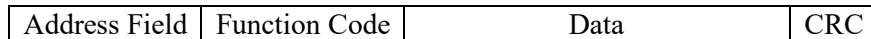

Figure 15 Modbus™ Frame Format

The Modbus ID Field is the unique Modbus™ address of each device on the network. The Function Code is the function to be performed. The Data contains read or write data and is formatted according to the function being performed. The CRC (Cyclic Redundancy Code) is used to detect errors in the frame. Frames with errors are invalid and ignored.

Modbus™ transactions consist of both a request by the controller and response from the device being addressed so there are two frames transferred for every transaction. Every request is evaluated by the CXT to determine if it is addressed to it, and if it falls within the register address range. If these two conditions are true, the CXT will then check to see if it is a valid Function Code. Function Codes supported by the CXT are:

- Function Code 03 (03h) – Read Holding Registers
- Function Code 06 (06h) – Write Single Register
- Function Code 16 (10h) – Write Multiple Registers

If an invalid function code is performed, the CXT will ignore the request by default and the controller will timeout and continue with the next transaction.

4.1.1 Modbus™ Exceptions

The CXT is capable of returning Modbus™ exceptions when it cannot service a Modbus™ request meant for that CXT. By default this is turned off since it can cause issues with some controllers that do not process Modbus™ exceptions (See Section 4.2.2.4). The following exception codes are supported and returned when Modbus™ exceptions are enabled:

Table 1 Exception Codes

Exception Code	Name	Meaning
01	Illegal Function	Unsupported function code. Only 03, 06 and 16 are supported.
02	Illegal Data Address	Invalid register address detected. If any request for registers outside of the valid register address for the CXT occurs, this exception code will be returned.

There are other exception codes defined in Modbus™ but these are the only ones used by the CXT.

NOTE: When using Teledyne Detcon controllers, Modbus exceptions should be turned off.

4.1.2 Modbus™ Broadcast Request

The Modbus™ broadcast request was introduced in the CXT to support commands to be executed across all CXT transceivers simultaneously. More specifically this is used to place all CXTs in a low power state for a specified time to conserve battery life. Only the transceivers (radio) are placed into a low power state, the CXT sensor will continue to operate normally. If none of the CXTs are battery powered then there is no need to issue a command to place the transceivers in low power mode.

According to the Modbus™ specification a broadcast request is defined as a request with the Address Field set to 0 and is used for writing only. There is no response returned as with normal Modbus™ transactions since all devices on the system are accessed at the same time. Both Function Codes 06 and 16 (writes) are supported with a broadcast request on the CXT.

Since there is no response on the broadcast request, there is a requirement to wait for a period of time before sending out the next request. This allows all slave devices to process the command before the next request is received. This is defined as the “turnaround delay”. This turnaround delay should be approximately 150 milliseconds for broadcast requests sent to the CXT. Controllers in general can meet this timing because it takes longer than this to generate the next request so it may be unnecessary to make any adjustments to meet this timing.

NOTE: Controllers that generate Modbus™ broadcast requests to the CXT must ensure a turnaround delay of 150ms is met otherwise the next request can cause the broadcast request to be overwritten and ignored.

Broadcast requests are not confined to commands to put the network in low power mode, but can be used where any normal write command is used.

4.2 Modbus™ Register Map & Description

When the CXT is assigned a Modbus™ address, the following registers become available to the controller for access. All CXT sensors implement this register set. Some registers are Read Only (R) and others are Read/Write (R/W) as shown by the R/W column. This equates to specific function codes where Read is function code 03 and Write is function code 06 or 16.

NOTE: A write to a Read Only register is allowed and returns a response, but it does not change the value of the register. In some devices this would return an exception code.

The following table is the register map for the CXT sensor and gives a brief description each register or register set. This information is only meant as a reference. The registers are divided into two sections, one for the CXT sensor and the other for the CXT transceiver. For a more detailed description of the Register Map please contact Teledyne Detcon.

Table 2 CXT-DM Register Map

Offset	Name	R/W	Comment
0000	CXT-DM-100 Device Type	R	= 36
0001	Range	R/W	Detectable Range
0002	Reading	R	Current Gas Reading
0003	Calibration Level	R/W	Auto Span Level
0004	Life	R	Sensor Life
0005	Sensor Faults	R	Fault bits
0006	Sensor Model	R	DM (set to 1)
0007	Days since Calibration	R	
0008	Reserved	R	
0009	Reserved	R	
0010	Sensor Temperature	R	
0011	DECIMAL	R/W	
0012	Temperature Compensation	R/W	
0013	Reserved	R	
0014	COUNTS	R/W	
0015	CONTROL	R/W	
0016	String	R	Set during production/test
0017	String	R	Set during production/test
0018	String	R	Set during production/test
0019	String	R	Set during production/test
0020	String	R	Set during production/test
0021	String	R	Set during production/test
0022	Reserved	R/W	NOT USED
0023	Sensor Controller Version	R	Year.Week
0024	Reserved	R	
0025	Reserved	R	
0026	Reserved	R	
0027	Wireless Controller Version	R	Major.Minor
0028	Reserved	R	
0029	Radio Firmware Version	R	00.Major
0030	Radio Firmware Version	R	Minor.Build
0031	Radio Software Version	R	Major.Minor
0032	Wireless ID High	R	00.XX
0033	Wireless ID Low	R	XX.XX
0034	RF Channel	R	Wireless RF Channel (Set in Display)
0035	Network ID	R	Defaults to RF Channel (Set in Display)
0036	Modbus Address	R	CXT Modbus Address (Set in Display)
RXT-320 Compatible Registers for Wireless Transceiver			
8192	RXT-320 Device Type	R	22 (for compatibility)
8193	Reserved	--	
8194	Reserved	--	
8195	Reserved	--	
8196	Reserved	--	
8197	Reserved	--	
8198	Reserved	--	
8199	Battery Life in Percent	R	Smart Battery Life remaining in percent
8200	Battery Life in Minute	R	Smart Battery Life remaining in minutes
8201	Wireless Controller Version	R	same as register 0027
8202	RF Update Rate	W	Number of seconds to power down transceiver
8203	Control	R/W	Wireless Control

Offset	Name	R/W	Comment
8204	Status	R	Wireless Status
8205	Input Voltage	R	Smart Battery voltage or Input Voltage to A/D
8206	Battery Error Count	R/W	Smart Battery read error count if detected
8207	Reserved	--	
8208	Timestamp[0]	R	Time since power applied -- Seconds High
8209	Timestamp[1]	R	Time since power applied -- Seconds Low
8210	Timestamp[2]	R	Time since power applied -- Milliseconds

4.2.1 CXT Sensor Registers

4.2.1.1 Sensor Faults – Register 0005

The sensor fault status register consists of High and Low Status Bits. These bits are set/reset as faults occur or are cleared. Each bit has a particular meaning:

Register #	High Byte	Low Byte
0005	Status Bits	Status Bits

Bits read as 0 are FALSE; bits read as 1 are TRUE

Status Bits High Byte:

Bit 15 – Reserved

Bit 14 – Calibration Mode

Bit 13 – Reserved

Bit 12 – Zero Fault

Bit 11 – Range Fault

Bit 10 – Reserved

Bit 9 – Clearing Fault

Bit 8 – Reserved

Status Bits Low Byte:

Bit 7 – Sensor Fault

Bit 6 – Processor Fault

Bit 5 – Memory Fault

Bit 4 – Reserved

Bit 3 – Reserved

Bit 2 – Temperature Fault

Bit 1 – Auto Span Fault

Bit 0 – Global Fault

4.2.2 CXT Transceiver Registers

4.2.2.1 Battery Info – Multiple Register

If a Teledyne Detcon smart battery pack is connected to the CXT, there are five registers associated with information about that battery. The CXT utilizes the I²C interface to read battery status and only one Teledyne Detcon battery pack can be read per CXT.

The controller can determine if a battery is present by reading the Status Register (register 8204). There are two bits in this sixteen bit register pertaining to the battery, Battery Detect – bit 4 (lowest bit is 0) and Battery Fault – bit 5. Both bits default to a value of 0. Battery Detect will be set once the first read of the battery over the I²C interface was successful. Battery Fault will be set if a battery was detected but the last read failed. Battery Fault is re-evaluated upon every read of the battery which is set to approximately every 5 seconds. Register 8206 (I²C Batt Read Fails) will increment by 4 each time there is a failure since there are 4 attempts before declaring failure. This register can be cleared by writing a 0 to it at any point.

Once the battery has been detected the controller can read the battery life (registers 8199 and 8200). The battery adjusts these values based upon the average current usage. If this usage varies widely over time it will take some time to re-adjust the battery life readings. For instance an Alarm Station with no alarms will consume a very small amount of battery but when Alarms are active this will jump to a much higher level of usage. So in this case battery life may go from several weeks down to several hours.

The battery life is presented in two forms, life remaining in percentage (register 8199) and life remaining in minutes (register 8200). The battery Life remaining is percentage is a value between 0 and 100 and battery life in minutes is an unsigned value between 0 and 65535. Both readings are generally necessary to provide appropriate feedback to the user. Life in minutes is the best for determining when to change the battery. For example if the user wanted to be notified a day before the battery needed to be changed, the user could set a threshold in the controller to be notified of low battery after 1440 minutes (1 day).

Since 65535 is the maximum value for life remaining in minutes, this represents a maximum of 45.5 days. The battery life for an application can be much greater than this value and will remain at a reading of 65535 until it drops below this. Life in percentage was added for this reason. Percentage will track starting at 100 percent and drop down as battery life decreases. The controller can therefore use both registers, one to represent usage in percentage to present to the user and then use the life in minutes to set a threshold on when a low battery condition exists for changing the battery.

4.2.2.2 Wireless Controller Version

This is set to a value based upon the version of firmware programmed into the RXT-320 microcontroller. It is stored as two byte value representing the major and minor revision numbers. So a 0113h (275 decimal) represents a major version of 01 and minor version of 13. As software is updated this will be incremented appropriately.

4.2.2.3 Register – Update Rate

The Update Rate represents the amount of time in seconds the CXT transceiver will be in a low power state. Its main purpose is to provide a mechanism to place all wireless transceivers in a system into a low power mode to conserve battery power. If there are no batteries used within the network of wireless transceivers this register would not be utilized.

Upon power up, this register is set to 0 and the CXT transceiver is not in low power mode. To place a network to low power mode the controller will generate a broadcast request (Modbus™ address = 0) and do a single write (function code 06) to register 8202 with the number of seconds the network should go into low power mode. During low power mode, there can be no access to any device on the network so changes in sensor readings will not be updated. Once a non-zero value is written to this register on all transceivers, they will begin counting down until the Update Rate register reaches zero, at which time all transceivers should be active again and ready for network communication. The controller will monitor the update rate time remaining by accessing Update Rate register on the RXT-320 (or equivalent) that it is attached to it. The Modbus™ interface remains active, only the wireless network is placed in a low power state. The value of this register can be between 0 and 65535 which allows a maximum low power time of 18.2 hours. Removal of power will reset Update Rate to 0 and the transceiver will be active again.

4.2.2.4 Register – Control

The CXT transceiver control register is generally unused and should not be written to normally. Using the control register, the CXT can be reset and Modbus™ exceptions can be enabled. Each bit in the control register can control a particular function and should be read first then modify the bits needed and written back. The default state of the register is 0. All reserved bits should always be set to a 0 when writing. The listing below shows the bit assignments.

Bit 15:	Reserved (set to 0)
Bit 14:	Reserved (set to 0)
Bit 13 – 12:	Reserved (set to 0)
Bit 11:	Modbus Exceptions Enabled
Bit 10 – 08:	Reserved (set to 0)
Bit 07:	Reset the microcontroller and wireless radio
Bit 06:	Reset the microcontroller
Bit 05 – 00:	Reserved (set to 0)

4.2.2.5 Register – Status

This register contains status of the CXT transceiver and some of the bits have already been covered in the battery description. These default to 0 upon reset. The bit assignment and description are given below.

Bit 15 – 08:	Reserved (set to 0)
Bit 07:	Reserved (set to 0)
Bit 06:	Reserved (set to 1)
Bit 05:	I2C Fault on last read of Battery Status
Bit 04:	Battery Detected
Bit 03:	Reserved (set to 0)
Bit 02:	Reserved (set to 1)
Bit 01:	Reserved (set to 0)
Bit 00:	Reserved (set to 0)

4.2.2.6 Register – Timestamp

Three registers are utilized to maintain a timestamp that increments on the microcontroller after power up. These are all set to 0 upon power up or a microcontroller reset. The first two registers 8208 and 8209 are internally combined into a single 32 bit register and incremented each second. The last register 8210 maintains the millisecond count and will count from 0 to 999 and start over again.

5. Service and Maintenance

Calibration Frequency

In most applications, monthly to quarterly span calibration intervals will assure reliable detection. However, industrial environments differ. Upon initial installation and commissioning, close frequency tests should be performed, weekly to monthly. Test results should be recorded and reviewed to determine a suitable calibration interval.

Visual Inspection

The Sensor should be inspected annually:

- Inspect the sensor for signs of corrosion, pitting, and water damage.
- Remove the Splash Guard and inspected it for blockage, broken, cracked, or missing pieces.
- For H2S Sensor assemblies, inspect CXT-DM Series Splashguard Adapter Assembly with integral filter (P/N 602-003552-100) for blockage of filter material.
- Inspect inside of the Junction Box for signs of water accumulation, signs of corrosion.
- Check wiring to ensure there are no loose or pinched wires and all connections are clean and tight.

Condensation Prevention Packet

A moisture condensation packet should be installed in every explosion proof Junction Box. The moisture condensation prevention packet will prevent the internal volume of the J-Box from condensing and accumulating moisture due to day-night humidity changes. This packet provides a critical function and should be replaced annually. Teledyne Detcon's PN is 960-202200-000.

5.1 Replacement of the batteries/battery pack

5.1.1 Units with 12V Smart Battery Pack

The CXT-DM Sensor incorporates a 'Low battery' fault message which will appear as an alternating display between the current gas reading and 'VOLT' on the sensor display. This fault will appear when the battery voltage drops below 7.5 volts. When the voltages drops below 7.2 volts the display will change to a steady 'VOLT' display, the sensor will then enter into 'Fault' mode, and the sensor will no longer provide a valid gas reading.

NOTE: The safety approvals require removing entire sensor assembly to a non-hazardous area before installing or changing out the batteries or battery pack.

1. Remove the cover from the J-box.
2. Unscrew battery bracket lid, and swing the lid away from the battery pack.
3. Remove the battery pack from the J-box, and replace with new battery pack.
4. Swing the lid back over the battery pack, and re-tighten screws in battery bracket lid.
5. Replace the cover on the J-box.

5.1.2 Units with D-size Non-Rechargeable Batteries

NOTE: The safety approvals require removing entire sensor assembly to a non-hazardous area before installing or changing out the batteries or battery pack.

1. Remove the cover from the J-box.
2. Unscrew battery bracket lid, and swing the lid away from the battery pack.
3. Remove the battery holder from the J-box.
4. Loosen the four 4-40 Philips Head Screws from the bottom of the battery pack. It is not necessary to remove the screws, they are captive head screws, and will not fall out of the assembly.
5. The orientation of batteries is marked on the inside of the cover and the holder. Remove the batteries from the battery holder.

6. Replace the batteries with the same type (Teledyne Detcon P/N 360-TL5930-000). Pay close attention to the orientation of the batteries. Installing the batteries incorrectly can cause damage to the batteries, the battery holder and the unit (refer to Figure 19). It is permissible to use only Tadiran Model TL-5930 batteries. **Do NOT** use regular 'D' size batteries, as this may cause damage to the sensor assembly.
7. Reinstall the bottom cover of the battery housing, and tighten the four 4-40 philips head screws to reassemble the battery holder.
8. Swing the lid back over the battery pack, and re-tighten screws in battery bracket lid.
9. Replace the cover on the J-box.

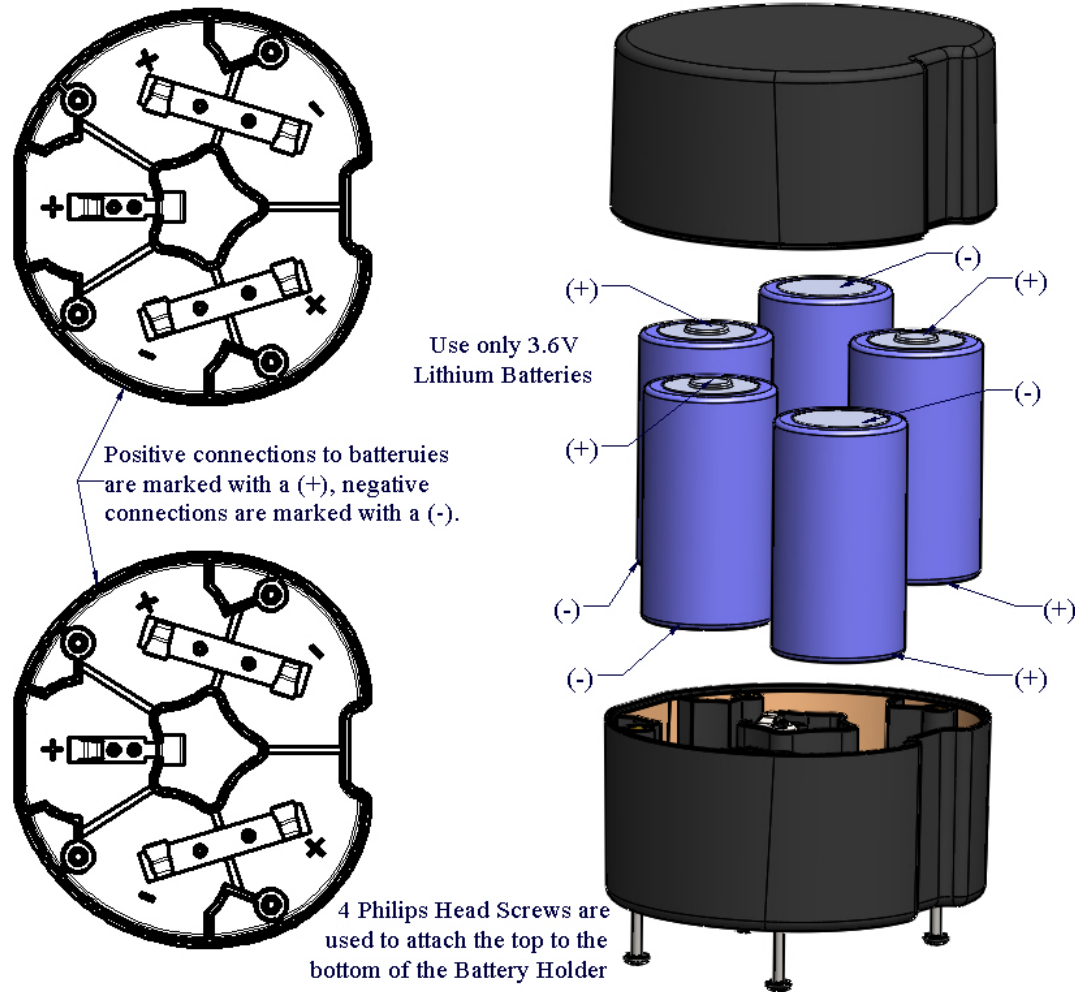

Figure 16 Battery Orientation Diagram

5.2 Replacement of Plug-in Sensor

NOTE: It is not necessary to remove power while changing the plug-in toxic gas sensor in order to maintain area classification, since it is intrinsically safe.

NOTE: Only replace the plug-in sensor with an authorized CXT-DM family of gas sensors.

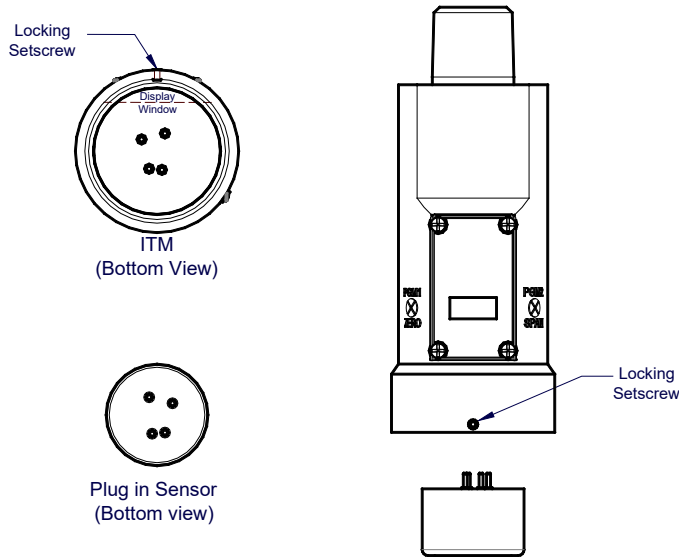

Figure 17 Sensor Cell and ITM Mating

1. Use a 1/16" Allen wrench to release the locking setscrew that locks the ITM and Splashguard Adapter Assembly together (One turn will suffice - Do not remove setscrew completely).
2. Remove splashguard. Unthread and remove the Splashguard Adapter Assembly from the ITM.
3. Gently pull the plug-in sensor out of the ITM. Verify the gas type and range of the new sensor cell is correct. Orient the new plug-in sensor so that it matches with the female connector pins. When properly aligned, press the sensor in firmly to make the proper connection.
4. Thread the Splashguard Adapter Assembly onto the ITM to a snug fit and tighten the locking setscrew using the 1/16" Allen wrench. Reinstall the splashguard.
5. Check and perform zero calibration and span calibration as per Section 3.3.

5.3 Replacement of ITM – Aluminum J-Box

1. Remove the power source to the sensor assembly, and remove the battery pack from the J-box. Disconnect all sensor wire connections at the Junction Box Terminal Board, taking note of the wire connections, and disconnect the RF cable connector.

NOTE: It is necessary to remove power to the Junction box while changing the ITM in order to maintain area classification.

2. Use a wrench and the wrench flats provided at the top section of the ITM and unthread the ITM until it can be removed.
3. Use a 1/8" Allen wrench to release the locking cap head screw that locks the ITM and Splashguard Adapter Assembly together (One turn will suffice - Do not remove setscrew completely).
4. Unthread and remove the Splashguard Adapter Assembly and Splash Guard from the ITM. These will be re-used with the new ITM.
5. Gently remove the plug-in toxic gas sensor from the old ITM and install it in the new ITM. Orient the plug-in sensor pins so that they matches the female connector pins on the new ITM and press the sensor in firmly to make proper connection.
6. Thread the Splashguard Adapter Assembly onto the new ITM until snug, tighten the locking cap head screw and reinstall Splash Guard.
7. Feed the sensor assembly wires and RF cable through the 3/4" female NPT port and thread the assembly into the J-box until tight and the ITM faces toward the front access point. Use the locking nut to secure the ITM in this position. Re-connect the sensor assembly wires to the terminal board inside the Junction Box. Re-connect the RF cable to the antenna cable.
8. Re-install the battery pack.
9. Check and/or perform Zero Calibration and Span Calibration per sections Section 3.3.

6. Troubleshooting Guide

If the ITM detects any functional errors the ITM will display the fault. If the sensor is experiencing a fault condition a momentary swipe of the magnet will cause the ITM to scroll the fault condition(s) across the display before the “←” or “→” prompt will appear.

The Display Error Codes are:

Auto Span Fault
 Temperature Fault
 Memory Fault
 Processor Fault
 Clearing Fault
 Range Fault
 Sensor Fault
 Zero Fault
 Sensor Fault 2

Some faults are self-explanatory, and if these faults occur and cannot be cleared the ITM should be replaced first to see if the fault will clear. Other faults may need further investigation. Some of the sensor problems, associated error codes, and resolutions are listed below.

Under-Range problems

Probable Cause: Sensor Baseline drifted lower, Interference gases,

- Perform Zero Calibration. Use Zero Air or N₂ source. (Section 3.3.1)
- Allow more time for zero stabilization if this is a biased sensor type.
- Execute successful Span Calibration. (Section 3.3.2)
- Replace plug-in toxic sensor if error continues.

Stability problems

Probable Causes: Failed Sensor, empty or close to empty Cal Gas Cylinder, problems with cal gas and delivery

- Check validity of span gas using pull tube or other means (check MFG date on cal gas cylinder).
- Use proper cal gas regulators and tubing for highly corrosive gases
- If using Splashguard with Integral Cal Port, must use Calibration Wind Guard or air movement can compromise span gas delivery.
- Check for obstructions affecting cal gas hitting sensor face (including being wet, blocked, or corroded). H₂S sensors assemblies use CXT-DM Series Splashguard Adapter Assembly with integral filter. Clean or replace if necessary.
- Replace the plug-in toxic sensor.

Clearing problem

Probable Causes: Failed Sensor, Cal Gas not removed at appropriate time, problems with cal gas and delivery, Background of Target Gas.

- The sensor must recover to < 5% of range in < 5 min after Span calibration is complete
- Use bottled air (zero air or N₂) if there is a known continuous background level.
- Check validity of span gas using pull tube or other means (check MFG date on cal gas cylinder).
- Use proper cal gas regulators and tubing for highly corrosive gases
- Check for obstructions affecting cal gas hitting sensor face (including being wet, blocked, or corroded). H₂S sensors assemblies use CXT_DM Series Splashguard Adapter Assembly with integral filter. Clean or replace if necessary.
- Replace the plug-in toxic sensor.

Poor Calibration Repeatability

Probable Causes: Failed Sensor, use of wrong Cal Gas or problems w/ cal gas and delivery, Interference Gases

- Check validity of span gas with regulator and sample tubing in place using pull tube or other means (check MFG date on cal gas cylinder).
- Use proper cal gas regulators and tubing for highly corrosive gases (HF, HCl, Cl₂, NH₃, HBR, F₂, etc.)
- Check for obstructions affecting cal gas hitting sensor face (including being wet, blocked, or corroded). H₂S sensors assemblies use CXT-DM Series Splashguard Adapter Assembly with integral filter. Clean or replace if necessary.
- Replace the plug-in toxic sensor.

Unstable Output/ sudden spiking

Possible Causes: Unstable power supply, inadequate grounding, or inadequate RFI protection.

- Verify Power source is stable.
- Verify field wiring is properly shielded and grounded.
- Contact Teledyne Detcon to optimize shielding and grounding.
- Add Teledyne Detcon’s RFI Protection Circuit accessory if problem is proven RFI induced.

Nuisance Alarms

- Check conduit for accumulated water and abnormal corrosion on terminal board.
- If nuisance alarms are happening at night, suspect condensation in conduit.
- Add or replace Teledyne Detcon’s Condensation Prevention Packet P/N 960-202200-000.
- Investigate the presence of other target gases that are causing cross-interference signals.
- Determine if cause is RFI induced.

Transmitter not responding

- Verify conduit has no accumulated water or abnormal corrosion.
- Verify required batteries are installed and have enough charge to power the sensor.
- Swap with a known-good ITM to determine if ITM is faulty.

Low Battery / Low Voltage Fault

Possible Cause: Lithium Ion batteries are depleted.

- Change out all of the Lithium Ion non-rechargeable ‘C’ or ‘D’ size batteries with new batteries.

NOTE: Contact the Teledyne Detcon Service Department for further troubleshooting assistance at 281-367-4100.

7. Customer Support and Service Policy

Teledyne Detcon Headquarters

Shipping Address: 14880 Skinner Road, Cypress, Texas 77429

Phone: 713.559.9200

- www.teledynegasandflamedetection.com
- [Teledyne Detcon-service@teledyne.com](mailto:Teledyne_Detcon-service@teledyne.com)
- [Teledyne Detcon-sales@teledyne.com](mailto:Teledyne_Detcon-sales@teledyne.com)

All Technical Service and Repair activities should be handled by the Teledyne Detcon Service Department via phone or email at contact information given above. RMA numbers should be obtained from the Teledyne Detcon Service Department prior to equipment being returned. For on-line technical service, customers should have ready the model number, part number, and serial number of product(s) in question.

All Sales activities (including spare parts purchase) should be handled by the Teledyne Detcon Sales Department via phone or email at contact information given above.

Warranty Notice

Teledyne Detcon Inc. warrants the Model CXT-DM gas sensor to be free from defects in workmanship of material under normal use and service for one year from the date of shipment on the transmitter electronics. See Warranty details in section 8.

Teledyne Detcon Inc. will repair or replace without charge any such equipment found to be defective during the warranty period. Full determination of the nature of, and responsibility for, defective or damaged equipment will be made by Teledyne Detcon Inc. personnel.

Defective or damaged equipment must be shipped to the Teledyne Detcon Inc. factory or representative from which the original shipment was made. In all cases, this warranty is limited to the cost of the equipment supplied by Teledyne Detcon Inc. The customer will assume all liability for the misuse of this equipment by its employees or other contracted personnel.

All warranties are contingent upon the proper use in the application for which the product was intended and does not cover products which have been modified or repaired without Teledyne Detcon Inc. approval, or which have been subjected to neglect, accident, improper installation or application, or on which the original identification marks have been removed or altered.

Except for the express warranty stated above, Teledyne Detcon Inc. disclaims all warranties with regard to the products sold. Including all implied warranties of merchantability and fitness and the express warranties stated herein are in lieu of all obligations or liabilities on the part of Teledyne Detcon Inc. for damages including, but not limited to, consequential damages arising out of, or in connection with, the performance of the product.

8. CXT-DM Sensor Warranty

Plug-in Sensor Warranty

Teledyne Detcon Inc. warrants, under normal intended use, each new plug-in sensor per the period specified in the Warranty column of Table 3 Sensor Specific Data (See section 9.2) and under the conditions described as follows: The warranty period begins on the date of shipment to the original purchaser. The sensor element is warranted to be free of defects in material and workmanship. Should any sensor fail to perform in accordance with published specifications within the warranty period, return the defective part to Teledyne Detcon, Inc., 14880 Skinner Road, Cypress, Texas 77429, for necessary repairs or replacement.

Terms & Conditions

- The original serial number must be legible on each sensor element base.
- Shipping point is FOB the Teledyne Detcon factory.
- Net payment is due within 30 days of invoice.
- Teledyne Detcon, Inc. reserves the right to refund the original purchase price in lieu of sensor replacement.

ITM Electronics Warranty

Teledyne Detcon Inc. warrants, under intended normal use, each new Compact Wireless Sensor ITM to be free from defects in material and workmanship for a period of one year from the date of shipment to the original purchaser. All warranties and service policies are FOB the Teledyne Detcon facility located in Cypress, Texas.

Terms & Conditions

- The original serial number must be legible on each ITM.
- Shipping point is FOB the Teledyne Detcon factory.
- Net payment is due within 30 days of invoice.

Teledyne Detcon, Inc. reserves the right to refund the original purchase price in lieu of ITM replacement.

9. Appendix

9.1 Specifications

Sensor Type:	Continuous diffusion/adsorption type 3-Electrode Electrochemical Sensor (2-Electrode for O ₂) Plug-in Replaceable Type
Sensor Life:	2 years typical
Measuring Ranges:	0-1ppm up to 0-10,000ppm (Toxic Gases) 0-1% up to 0-25% volume (O ₂)
Accuracy/ Repeatability:	±2% of full-range (Toxic Gases) ±1% of full-range (O ₂)
Response Time:	T90 < 30 seconds typical (See Sensor Table)
Electrical Classification: (CXT-DM)	Explosion proof Canada and US (NRTL) Class I, Division 1, Groups C and D (Tamb = -40°C to +50°C) Class I, Zone 1, Group IIB ATEX/IECEX Ex d ib IIB T4 Gb (Tamb = -40°C to +50°C) SIRA 14ATEX1034X EN IEC 60079-0:2018, EN 60079-1:2014, EN 60079-11:2012
Warranty:	Electronics – 1 year Sensor – See Table 3 Sensor Specific Data

Environmental Specifications

Operating Temperature:	-40°C to +50°C typical (See Table 3 Sensor Specific Data)
Storage Temperature:	-35°C to +55°C typical
Operating Humidity:	10-95% RH Continuous Duty (See Table 3 Sensor Specific Data) 0-100% RH Short-Term Duration Only
Operating Pressure:	Ambient ± 10%
Air Velocity:	0-5 meters/second

Electrical Specifications

Input Voltage:	7.2-30 VDC
Power Consumption:	20mW (Low Power Mode) 100mW (Typical) 5W (With Strobe Active)
RFI/EMI Protection:	Complies with EN61326

Mechanical Specifications (ITM Only)

Length:	ITM - 5.165 inches (131 mm), 8.5 inches (215mm) with Splash Guard
Width:	2.2 inches (55 mm)
Weight:	2.5 lbs (1.2 Kg)
Mechanical Connection:	¾" Male NPT threaded connection with locking nut
Electrical Connection:	four 18 gauge wire leads - 5.5" long with RF Cable terminated at SMA

9.2 Sensor Specification Data

Table 3 Sensor Specific Data

Gas	GasName	Part Number ¹	Response Time (seconds)	SpanDrift	Temperature Range °C	Humidity Range%	Warranty
O ₂	Oxygen	371-343400-025	T95<30	<5%signal loss/year	-20 to+50	15 to 90	2 years
C ₂ H ₃ O	Acetaldehyde	371-12EA00-100	T90<140	<5%signal loss/year	-20 to+50	15 to 90	2 years
NH ₃	Ammonia	371-171700-100	T90<90	<2%signal loss/month	-20 to+50	15 to 90	2 years
AsH ₃	Arsine	371-191900-001	T90<60	<5%signal loss/month	-20 to+40	20 to 95	1.5 years
Br ₂	Bromine	371-747500-005	T90<60	<2%signal loss/month	-20 to+50	15 to 90	2 years
C ₄ H ₆	Butadiene	371-12EB00-100	T90<140	<5%signal loss/year	-20 to+50	15 to 90	2 years
CO	Carbon Monoxide	371-444400-100	T90=30	<5%signal loss/year	-40 to+50	15 to 90	3 years
Cl ₂	Chlorine	371-747400-010	T90<60	<2%signal loss/month	-20 to+50	15 to 90	2 years
ClO ₂ (>10ppm)	Chlorine Dioxide	371-777700-001	T90<60	<2%signal loss/month	-20 to+50	15 to 90	2 years
ClO ₂ (<=10ppm)	Chlorine Dioxide	371-282800-050	T90<120	<1%signal loss/month	-20 to+40	10 to 95	2 years
B ₂ H ₆	Diborane	371-192100-005	T90<60	<5%signal loss/month	-20 to+40	20 to 95	1.5 years
C ₂ H ₅ OH	Ethanol	371-12EO00-100	T90<140	<5%signal loss/year	-20 to+50	15 to 90	2 years
C ₂ H ₅ SH	Ethyl Mercaptan	371-24EZ00-100	T90<45	<2%signal loss/month	-40 to+50	15 to 90	2 years
C ₂ H ₄	Ethylene	371-12ED00-100	T90<140	<5%signal loss/year	-20 to+50	15 to 90	2 years
F ₂	Fluorine	371-272700-001	T90<80	<5%signal loss/year	-10 to+40	10 to 95	1.5 years
GeH ₄	Germane	371-232500-002	T90<60	<1%signal loss/month	-20 to+40	20 to 95	1.5 years
N ₂ H ₄	Hydrazine	371-262600-001	T90<120	<5%signal loss/month	-10 to+40	10 to 95	1 year
HBr	Hydrogen Bromide	371-090800-030	T90<70	<3%signal loss/month	-20 to+40	10 to 95	1.5 years
HCl	Hydrogen Chloride	371-090900-030	T90<70	<2%signal loss/month	-20 to+40	10 to 95	1.5 years
HCN	Hydrogen Cyanide	371-131300-030	T90<40	<5%signal loss/month	-40 to+40	5 to 95	2 years
HF	Hydrogen Fluoride	371-333300-010	T90<90	<10%signal loss/month	-20 to+35	10 to 80	1.5 years
H ₂ S	Hydrogen Sulfide	371-242400-100	T80<30	<2%signal loss/month	-40 to+50	15 to 90	2 years
CH ₃ OH	Methanol	371-12EE00-100	T90<140	<5%signal loss/year	-20 to+50	15 to 90	2 years
CH ₃ SH	Methyl Mercaptan	371-24EK00-100	T90<45	<2%signal loss/month	-40 to+50	15 to 90	2 years
NO	Nitric Oxide	371-949400-100	T90=10	<2%signal loss/month	-20 to+50	15 to 90	3 years
NO ₂	Nitrogen Dioxide	371-646400-010	T90<40	<2%signal loss/month	-20 to+50	15 to 90	2 years
O ₃	Ozone	371-999900-001	T90<120	<1%signal loss/month	-10 to+40	10 to 95	2 years

¹ The last three digits of the Part Number are the range of the sensor cell. I.E. “-100” is a 100ppm range.

Gas	GasName	Part Number ¹	Response Time (seconds)	SpanDrift	Temperature Range °C	Humidity Range%	Warranty
COCl ₂	Phosgene	371-414100-001	T90<120	<1%signal loss/month	-20 to+40	10 to 95	1.5 years
PH ₃	Phosphine	371-192000-005	T90<30	<1%signal loss/month	-20 to+40	20 to 95	1.5 years
SiH ₄	Silane	371-232300-050	T90<60	<1%signal loss/month	-20 to+40	20 to 95	1.5 years
SO ₂	Sulfur Dioxide	371-555500-020	T90=20	<2%signal loss/month	-20 to+50	15 to 90	2 years

¹ The last three digits of the Part Number are the range of the sensor cell. I.E. “-100” is a 100ppm range.

9.3 Interference Table

Refer to Table 4 Interfering Gases to match the interfering gas symbol with the gas name. Then refer to Table 5 Cross Interference Table which extends for 5 pages, with each sensor specific gas repeated in each section of the table, for a column listing of 40 gases. The list is followed by a row of 14 possible interfering gases per page. Review each page for the applicable sensor gas and then scan across the row for possible interference gases.

Table 4 Interfering Gases

Acetaldehyde	C ₂ H ₃ O	Dimethyl Sulfide	C ₂ H ₆ S	Methane	CH ₄
Acetylene	C ₂ H ₂	Disilane	Si ₂ H ₆	Methanol	CH ₃ OH
Acrylonitrile	C ₃ H ₃ N	Epichlorohydrin	C ₃ H ₅ OCl	Methyl-ethyl-ketone	C ₄ H ₈ O
Alcohols	Alcohols	Ethanol	C ₂ H ₅ OH	Methyl Mercaptan	CH ₃ SH
Amines	Amines	Ethyl Mercaptan	C ₂ H ₅ SH	Nitric Oxide	NO
Ammonia	NH ₃	Ethylene	C ₂ H ₄	Nitrogen	N ₂
Arsenic Trifluoride	AsF ₃	Ethylene Oxide	C ₂ H ₄ O	Nitrogen Dioxide	NO ₂
Arsenic Pentafluoride	AsF ₅	Fluorine	F ₂	Ozone	O ₃
Arsine	AsH ₃	Formaldehyde	CH ₂ O	Phosgene	COCl ₂
Boron Trifluoride	BF ₃	Germane	GeH ₄	Phosphine	PH ₃
Bromine	Br ₂	Hydrazine	N ₂ H ₄	Phosphorous Trifluoride	PF ₃
Butadiene	C ₄ H ₆	Hydrocarbons	C-H's	Silane	SiH ₄
Buten-1	Buten-1	Hydrocarbons (unsaturated)	C-H's (μ)	Silicon	Si
Carbon Dioxide	CO ₂	Hydrogen	H ₂	Silicon Tetra Fluoride	SiF ₄
Carbon Disulfide	CS ₂	Hydrogen Bromide	HBr	Sulfur Dioxide	SO ₂
Carbon Oxide Sulfide	COS	Hydrogen Chloride	HCl	Tetrahydrothiophene	C ₄ H ₈ S
Carbon Monoxide	CO	Hydrogen Cyanide	HCN	Thiophane	C ₄ H ₄ S
Carbonyl Sulfide	CS	Hydrogen Fluoride	HF	Toluene	C ₆ H ₅ CH ₃
Chlorine	Cl ₂	Hydrogen Selenide	HSe	Tungsten Hexafluoride	WF ₆
Chlorine Dioxide	ClO ₂	Hydrogen Sulfide	H ₂ S	Vinyl Acetate	C ₄ H ₆ O ₂
Chlorine Trifluoride	ClF ₃	Dimethyl Sulfide	C ₂ H ₆ S	Vinyl Chloride	C ₂ H ₃ Cl
Diborane	B ₂ H ₆				

Table 5 Cross Interference Table

Gas	C ₂ H ₃ O	C ₂ H ₂	C ₃ H ₃ N	Alcohols	Amines	NH ₃	AsF ₃	AsF ₅	AsH ₃	BF ₃	Br ₂	C ₄ H ₆	Buten-1
C ₂ H ₃ O	n/a	40=340	40=75	n/d	n/d	n/d	n/d	n/d	n/d	n/d	n/d	40=170	n/d
C ₃ H ₃ N	75=40	75=340	n/a	n/d	n/d	n/d	n/d	n/d	n/d	n/d	n/d	75=170	n/d
NH ₃	n/d	n/d	n/d	n/d	n/d	n/d	n/d	n/d	n/d	n/d	n/d	n/d	n/d
AsH ₃	n/d	n/d	n/d	n/d	n/d	100=0.01	n/d	n/d	n/a	n/d	n/d	n/d	n/d
Br ₂	n/d	n/d	n/d	n/d	n/d	n/d	n/d	n/d	n/d	n/d	n/a	n/d	n/d
C ₄ H ₆	170=40	170=340	170=75	n/d	n/d	n/d	n/d	n/d	n/d	n/d	n/d	n/a	n/d
CS ₂	140=40	140=340	140=75	n/d	n/d	n/d	n/d	n/d	n/d	n/d	n/d	140=170	n/d
CO	n/d	n/d	n/d	n/d	n/d	n/d	n/d	n/d	n/d	n/d	n/d	n/d	n/d
Cl ₂	n/d	n/d	n/d	n/d	n/d	n/d	n/d	n/d	n/d	n/d	1=0.55	n/d	n/d
ClO ₂ (>10ppm)	n/d	n/d	n/d	n/d	n/d	n/d	n/d	n/d	n/d	n/d	1=0.18	n/d	n/d
ClO ₂ (=10ppm)	n/d	n/d	n/d	n/d	n/d	n/d	n/d	n/d	n/d	n/d	n/d	n/d	n/d
B ₂ H ₆	n/d	n/d	n/d	n/d	n/d	100=0.013	n/d	n/d	0.15=0.2	n/d	n/d	n/d	n/d
C ₃ H ₅ OCl	50=40	50=340	50=75	n/d	n/d	n/d	n/d	n/d	n/d	n/d	n/d	50=170	n/d
C ₂ H ₅ OH	180=40	180=340	180=75	n/d	n/d	n/d	n/d	n/d	n/d	n/d	n/d	180=170	n/d
C ₂ H ₅ SH	n/d	n/d	n/d	n/d	n/d	n/d	n/d	n/d	n/d	n/d	n/d	n/d	n/d
C ₂ H ₄	220=40	220=340	220=75	n/d	n/d	n/d	n/d	n/d	n/d	n/d	n/d	220=170	n/d
F ₂	n/d	n/d	n/d	1000=0	n/d	n/d	n/d	n/d	0.1=0	n/d	yes n/d	n/d	n/d
GeH ₄	n/d	n/d	n/d	n/d	n/d	100=<1	n/d	n/d	0.2=0.14	n/d	n/d	n/d	n/d
N ₂ H ₄	n/d	n/d	n/d	1000=0	n/d	200=0.04	n/d	n/d	0.1=0.1	n/d	n/d	n/d	n/d
HBr	n/d	n/d	n/d	1000=0	no	n/d	n/d	n/d	0.1=0.3	n/d	n/d	n/d	n/d
HCl	n/d	n/d	n/d	1000=0	no	n/d	n/d	n/d	0.1=0.3	n/d	n/d	n/d	n/d
HCN	n/d	n/d	n/d	1000=0	n/d	n/d	n/d	n/d	0.1=0	n/d	yes n/d	n/d	n/d
HF	n/d	n/d	n/d	1000=0	n/d	n/d	yes n/d	yes n/d	0.1=0	yes n/d	n/d	n/d	n/d
H ₂ S	n/d	n/d	n/d	n/d	n/d	n/d	n/d	n/d	n/d	n/d	n/d	n/d	n/d
CH ₃ OH	415=40	415=340	415=75	n/d	n/d	n/d	n/d	n/d	n/d	n/d	n/d	415=170	n/d
CH ₃ SH	n/d	n/d	n/d	n/d	n/d	n/d	n/d	n/d	n/d	n/d	n/d	275=170	n/d
NO	n/d	n/d	n/d	n/d	n/d	n/d	n/d	n/d	n/d	n/d	n/d	n/d	n/d
NO ₂	n/d	n/d	n/d	n/d	n/d	n/d	n/d	n/d	n/d	n/d	n/d	n/d	n/d
O ₃	n/d	n/d	n/d	n/d	n/d	n/d	n/d	n/d	0.1=0.05	n/d	yes n/d	n/d	n/d
COCl ₂	n/d	n/d	n/d	1000=0	n/d	50=0.5	n/d	n/d	n/d	n/d	n/d	n/d	n/d
PH ₃	n/d	n/d	n/d	n/d	n/d	100=0.01	n/d	n/d	1=1	n/d	n/d	n/d	n/d
SiH ₄	n/d	n/d	n/d	n/d	n/d	100=<1	n/d	n/d	0.2=0.14	n/d	n/d	n/d	n/d
SO ₂	n/d	n/d	n/d	n/d	n/d	n/d	n/d	n/d	n/d	n/d	n/d	n/d	n/d
C ₄ H ₆ O ₂	200=40	200=340	200=75	n/d	n/d	n/d	n/d	n/d	n/d	n/d	n/d	200=170	n/d
C ₂ H ₃ Cl	200=40	200=340	200=75	n/d	n/d	n/d	n/d	n/d	n/d	n/d	n/d	200=170	n/d

n/a – not applicable

n/d – no data

Table 5 Cross Interference Table (pg.2)

Gas	CO ₂	CS ₂	CO	COS	CL ₂	CLO ₂	CLF ₃	B ₂ H ₆	C ₂ H ₆ S	Si ₂ H ₆	C ₃ H ₅ OCL	C ₂ H ₅ OH	F ₂
C ₂ H ₃ O	n/d	40=140	40=100	40=135	n/d	n/d	n/d	n/d	40=150	n/d	40=50	40=180	n/d
C ₃ H ₃ N	n/d	75=140	75=100	75=135	n/d	n/d	n/d	n/d	75=150	n/d	75=50	75=180	n/d
NH ₃	n/d	n/d	300=8	n/d	1=-1	10%=-15	n/d	n/d	n/d	n/d	n/d	n/d	n/d
AsH ₃	5000=0	n/d	300=0	n/d	0.5=-0.04	n/d	n/d	0.2=0.15	n/d	5=yes n/d	n/d	n/d	n/d
Br ₂	n/d	n/d	300=0	n/d	1=2	1=6	n/d	n/d	n/d	n/d	n/d	n/d	n/d
C ₄ H ₆	n/d	170=140	170=100	170=135	n/d	n/d	n/d	n/d	170=150	n/d	170=50	170=180	n/d
CS ₂	n/d	n/a	140=100	140=135	n/d	n/d	n/d	n/d	140=150	n/d	140=50	140=180	n/d
CO	n/d	n/d	n/a	n/d	1=0	n/d	n/d	n/d	n/d	n/d	n/d	200=0	n/d
Cl ₂	n/d	n/d	300=0	n/d	n/a	n/d	n/d	n/d	n/d	n/d	n/d	n/d	n/d
ClO ₂ (>10ppm)	n/d	n/d	300=0	n/d	3=1	n/a	n/d	n/d	n/d	n/d	n/d	n/d	n/d
ClO ₂ (=10ppm)	5000=0	n/d	1000=0	n/d	1=0.9	n/a	yes n/d	0.1=0	n/d	n/d	n/d	n/d	yes n/d
B ₂ H ₆	5000=0	n/d	300=0	n/d	0.5=-0.05	n/d	n/d	n/a	n/d	5=yes n/d	n/d	n/d	n/d
C ₃ H ₅ OCl	n/d	50=140	50=100	50=135	n/d	n/d	n/d	n/d	50=150	n/d	n/a	50=180	n/d
C ₂ H ₅ OH	n/d	180=140	180=100	180=135	n/d	n/d	n/d	n/d	180=150	n/d	180=50	n/a	n/d
C ₂ H ₅ SH	n/d	n/d	300=5	n/d	1=-0.6	n/d	n/d	n/d	n/d	n/d	n/d	n/d	n/d
C ₂ H ₄	n/d	220=140	220=100	220=135	n/d	n/d	n/d	n/d	220=150	n/d	220=50	220=180	n/d
F ₂	5000=0	n/d	1000=0	n/d	1=1.3	n/d	n/d	n/d	n/d	n/d	n/d	n/d	n/a
GeH ₄	5000=0	n/d	300=0	n/d	0.5=-0.04	n/d	n/d	0.2=0.11	n/d	5=yes n/d	n/d	n/d	n/d
N ₂ H ₄	5000=0	n/d	1000=0	n/d	1=0	n/d	n/d	n/d	n/d	n/d	n/d	n/d	n/d
HBr	5000=0	n/d	1000=0	n/d	5=1	n/d	yes n/d	n/d	n/d	n/d	n/d	n/d	n/d
HCl	5000=0	n/d	1000=0	n/d	5=1	n/d	1=yes n/d	n/d	n/d	n/d	n/d	n/d	n/d
HCN	5000=0	n/d	1000=0	n/d	5=-1	n/d	n/d	n/d	n/d	n/d	n/d	n/d	n/d
HF	5000=0	n/d	1000=0	n/d	1=0.4	n/d	yes n/d	0.1=0	n/d	n/d	n/d	n/d	yes n/d
H ₂ S	n/d	n/d	300=1.5	n/d	1=-0.2	n/d	n/d	n/d	n/d	n/d	n/d	n/d	n/d
CH ₃ OH	n/d	415=140	415=100	415=135	n/d	n/d	n/d	n/d	415=150	n/d	415=50	415=180	n/d
CH ₃ SH	n/d	n/d	300=3	n/d	1=-0.4	n/d	n/d	n/d	n/d	n/d	n/d	n/d	n/d
NO	n/d	n/d	300=0	n/d	1=0	n/d	n/d	n/d	n/d	n/d	n/d	n/d	n/d
NO ₂	n/d	n/d	300=0	n/d	1=-1	n/d	n/d	n/d	n/d	n/d	n/d	n/d	n/d
O ₃	5000=0	n/d	300=0	n/d	1=1.4	0.1=0.12	1=1(theory)	n/d	n/d	n/d	n/d	n/d	0.1=0.07
COCl ₂	5000=0	n/d	1000=0	n/d	1=0	n/d	n/d	n/d	n/d	n/d	n/d	n/d	n/d
PH ₃	5000=0	n/d	300=0	n/d	0.5=-0.04	n/d	n/d	0.2=0.15	n/d	5=yes n/d	n/d	n/d	n/d
SiH ₄	5000=0	n/d	300=0	n/d	0.5=-0.04	n/d	n/d	0.2=0.11	n/d	5=yes n/d	n/d	n/d	n/d
SO ₂	n/d	n/d	300=<5	n/d	1=<0.5	n/d	n/d	n/d	n/d	n/d	n/d	n/d	n/d
C ₄ H ₆ O ₂	n/d	200=140	200=100	200=135	n/d	n/d	n/d	n/d	200=150	n/d	200=50	200=180	n/d
C ₂ H ₃ Cl	n/d	200=140	200=100	200=135	n/d	n/d	n/d	n/d	200=150	n/d	200=50	200=180	n/d

n/a – not applicable

n/d – no data

Table 5 Cross Interference Table (pg.3)

Gas	C ₂ H ₄	C ₂ H ₄ O	CH ₂ O	GeH ₄	N ₂ H ₄	C-H's	C-H's (U)	H ₂	HBr	HCL	HCN	HF	I ₂
C ₂ H ₃ O	40=220	40=275	40=330	N/d	n/d	n/d	n/d	n/d	n/d	n/d	n/d	n/d	n/d
C ₃ H ₃ N	75=220	75=275	75=330	N/d	n/d	n/d	n/d	n/d	n/d	n/d	n/d	n/d	n/d
NH ₃	100=0	n/d	n/d	N/d	n/d	n/d	n/d	200=4	n/d	5=-3	10=0	n/d	n/d
AsH ₃	n/d	n/d	n/d	1=0.4	n/d	%range=0	n/d	3000=0	n/d	5=0	10=0.1	4=0	n/d
Br ₂	100=0	n/d	n/d	N/d	n/d	n/d	n/d	100=0	n/d	5=0	10=0	n/d	n/d
C ₄ H ₆	170=220	170=275	170=330	N/d	n/d	n/d	n/d	n/d	n/d	n/d	n/d	n/d	n/d
CS ₂	140=220	140=275	140=330	N/d	n/d	n/d	n/d	n/d	n/d	n/d	n/d	n/d	n/d
CO	100=<100	n/d	n/d	N/d	n/d	n/d	n/d	100=<60	n/d	5=0	10=<2	n/d	n/d
Cl ₂	100=0	n/d	n/d	N/d	n/d	n/d	n/d	100=0	n/d	5=0	10=0	n/d	n/d
ClO ₂ (>10ppm)	100=0	n/d	n/d	N/d	n/d	n/d	n/d	100=0	n/d	5=0	10=0	n/d	n/d
ClO ₂ (=10ppm)	n/d	n/d	n/d	1=0	n/d	%range=0	n/d	1%=0	n/d	n/d	n/d	n/d	n/d
B ₂ H ₆	n/d	n/d	n/d	1=0.53	n/d	%range=0	n/d	3000=0	n/d	5=0	10=0.13	4=0	n/d
C ₃ H ₅ OCl	50=220	50=275	50=330	N/d	n/d	n/d	n/d	n/d	n/d	n/d	n/d	n/d	n/d
C ₂ H ₅ OH	180=220	180=275	180=330	N/d	n/d	n/d	n/d	n/d	n/d	n/d	n/d	n/d	n/d
C ₂ H ₅ SH	100=0	n/d	n/d	N/d	n/d	n/d	n/d	1%=<15	n/d	5=0	10=0	n/d	n/d
C ₂ H ₄	n/a	220=275	220=330	n/d	n/d	n/d	n/d	n/d	n/d	n/d	n/d	n/d	n/d
F ₂	n/d	n/d	n/d	n/d	n/d	%range=0	n/d	1%=0	n/d	5=0	1=-3	3=0	n/d
GeH ₄	n/d	n/d	n/d	n/a	n/d	%range=0	n/d	3000=0	n/d	5=0	10=1	4=0	n/d
N ₂ H ₄	n/d	n/d	n/d	n/d	n/a	%range=0	n/d	1000=0	n/d	5=0.1	n/d	3=0	n/d
HBr	n/d	n/d	n/d	n/d	n/d	%range=0	n/d	1%=0	n/a	1=1	15=1	3=0	n/d
HCl	n/d	n/d	n/d	1=n/d	n/d	%range=0	n/d	1%=0	1=1	n/a	15=1	3=0	n/d
HCN	n/d	n/d	n/d	n/d	n/d	%range=0	n/d	1000=0	n/d	5=0	n/a	3=0	n/d
HF	n/d	n/d	n/d	1=0	n/d	%range=0	n/d	1%=0	n/d	5=3.3	n/d	n/a	n/d
H ₂ S	100=0	n/d	n/d	n/d	n/d	n/d	n/d	1%=<5	n/d	5=0	10=0	n/d	n/d
CH ₃ OH	415=220	415=275	415=330	n/d	n/d	n/d	n/d	n/d	n/d	n/d	n/d	n/d	n/d
CH ₃ SH	100=0	n/d	n/d	n/d	n/d	n/d	n/d	1%=<10	n/d	5=0	10=0	n/d	n/d
NO	100=0	n/d	n/d	n/d	n/d	n/d	n/d	100=0	n/d	5=<1	10=0	n/d	n/d
NO ₂	100=0	n/d	n/d	n/d	n/d	n/d	n/d	100=0	n/d	5=0	10=0	n/d	n/d
O ₃	n/d	n/d	n/d	n/d	n/d	n/d	n/d	1%=0.003	n/d	10=0	10=0.03	5=0	yes n/d
COCl ₂	n/d	n/d	n/d	n/d	n/d	%range=0	n/d	1%=0	n/d	5=0	5=0	3=0	n/d
PH ₃	n/d	n/d	n/d	1=0.4	n/d	%range=0	n/d	3000=0	n/d	5=0	10=0.1	4=0	n/d
SiH ₄	n/d	n/d	n/d	1=1.0	n/d	%range=0	n/d	3000=0	n/d	5=0	10=1	4=0	n/d
SO ₂	100=0	n/d	n/d	n/d	n/d	n/d	n/d	100=0	n/d	5=0	10=<5	n/d	n/d
C ₄ H ₆ O ₂	200=220	200=275	200=330	n/d	n/d	n/d	n/d	n/d	n/d	n/d	n/d	n/d	n/d
C ₂ H ₃ Cl	200=220	200=275	200=330	n/d	n/d	n/d	n/d	n/d	n/d	n/d	n/d	n/d	n/d

n/a – not applicable

n/d – no data

Table 5 Cross Interference Table (pg.4)

Gas	HSe	H ₂ S	C ₃ H ₈ O	CH ₄	CH ₃ OH	C ₄ H ₈ O	CH ₃ SH	NO	N ₂	NO ₂	O ₃	COCL ₂	PH ₃
C ₂ H ₃ O	n/d	n/d	n/d	n/d	40=415	n/d	40=275	n/d	n/d	n/d	n/d	n/d	n/d
C ₃ H ₃ N	n/d	n/d	n/d	n/d	75=415	n/d	75=275	n/d	n/d	n/d	n/d	n/d	n/d
NH ₃	n/d	15=30	n/d	n/d	n/d	n/d	n/d	35=6	n/d	5=-1	n/d	n/d	n/d
AsH ₃	0.05=0.005	1=0	n/d	n/d	n/d	n/d	n/d	n/d	100%=0	n/d	n/d	n/d	0.1=0.11
Br ₂	n/d	15=-1.5	n/d	n/d	n/d	n/d	n/d	35=0	n/d	5=-10	n/d	n/d	n/d
C ₄ H ₆	n/d	n/d	n/d	n/d	170=415	n/d	170=275	n/d	n/d	n/d	n/d	n/d	n/d
CS ₂	n/d	n/d	n/d	n/d	140=415	n/d	140=275	n/d	n/d	n/d	n/d	n/d	n/d
CO	n/d	15<0.3	n/d	n/d	n/d	n/d	n/d	35=7	n/d	5=0.5	n/d	n/d	n/d
Cl ₂	n/d	15=-0.75	n/d	n/d	n/d	n/d	n/d	35=0	n/d	5=-5	n/d	n/d	n/d
ClO ₂ (>10ppm)	n/d	15=0.25	n/d	n/d	n/d	n/d	n/d	35=0	n/d	5=1.66	n/d	n/d	n/d
ClO ₂ (=10ppm)	n/d	10=0.015	n/d	n/d	n/d	n/d	n/d	n/d	n/d	yes n/d	yes n/d	n/d	n/d
B ₂ H ₆	0.05=0.006	1=0	n/d	n/d	n/d	n/d	n/d	n/d	100%=0	n/d	n/d	n/d	0.1=0.14
C ₃ H ₅ OCl	n/d	n/d	n/d	n/d	50=415	n/d	50=275	n/d	n/d	n/d	n/d	n/d	n/d
C ₂ H ₅ OH	n/d	n/d	n/d	n/d	180=415	n/d	180=275	n/d	n/d	n/d	n/d	n/d	n/d
C ₂ H ₅ SH	n/d	1:03	n/d	n/d	n/d	n/d	5=8	35<6	n/d	5=-1.5	n/d	n/d	n/d
C ₂ H ₄	n/d	n/d	n/d	n/d	220=415	n/d	220=275	n/d	n/d	n/d	n/d	n/d	n/d
F ₂	n/d	1=-1.5	n/d	n/d	n/d	n/d	n/d	n/d	100%=0	1=0.05	0.1=0.2	n/d	n/d
GeH ₄	0.05=0.005	1=0	n/d	n/d	n/d	n/d	n/d	n/d	100%=0	n/d	n/d	n/d	0.1=0.13
N ₂ H ₄	n/d	1=0.1	n/d	n/d	n/d	n/d	n/d	n/d	100%=0	1=-0.25	0.1=-0.1	n/d	0.3=0.1
HBr	0.1=0	10=2.75	n/d	n/d	n/d	n/d	n/d	n/d	100%=0	n/d	n/d	0.1=0	0.1=0.3
HCl	0.1=0	10=2.75	n/d	n/d	n/d	n/d	n/d	n/d	100%=0	n/d	n/d	0.1=0	0.1=0.3
HCN	n/d	10=0	n/d	n/d	n/d	n/d	n/d	n/d	100%=0	10=-12	0.1=0	n/d	0.3=0
HF	n/d	10=0	n/d	n/d	n/d	n/d	n/d	n/d	100%=0	10=0.1	n/d	n/d	0.1=0
H ₂ S	n/d	n/a	n/d	n/d	n/d	n/d	2:01	35<2	n/d	5=-0.5	n/d	n/d	n/d
CH ₃ OH	n/d	n/d	n/d	n/d	n/a	n/d	415=275	n/d	n/d	n/d	n/d	n/d	n/d
CH ₃ SH	n/d	1:02	n/d	n/d	n/d	n/d	n/a	35<4	n/d	5=-1.0	n/d	n/d	n/d
NO	n/d	15=-5	n/d	n/d	n/d	n/d	n/d	100=0	n/d	5<1.5	n/d	n/d	n/d
NO ₂	n/d	15=-0.75	n/d	n/d	n/d	n/d	n/d	35=0	n/d	n/a	n/d	n/d	n/d
O ₃	n/d	1=-.015	n/d	n/d	n/d	n/d	n/d	10=0	100%=0	1=0.7	n/a	n/d	0.3=0.03
COCl ₂	n/d	1=0	n/d	n/d	n/d	n/d	n/d	n/d	100%=0	n/d	n/d	n/a	0.3=0
PH ₃	0.05=0.005	1=0	n/d	n/d	n/d	n/d	n/d	n/d	100%=0	n/d	n/d	n/d	n/a
SiH ₄	0.05=0.005	1=0	n/d	n/d	n/d	n/d	n/d	n/d	100%=0	n/d	n/d	n/d	0.1=0.13
SO ₂	n/d	15=0	n/d	n/d	n/d	n/d	n/d	35=0	n/d	5=-5	n/d	n/d	n/d
C ₄ H ₆ O ₂	n/d	n/d	n/d	n/d	200=415	n/d	200=275	n/d	n/d	n/d	n/d	n/d	n/d
C ₂ H ₃ Cl	n/d	n/d	n/d	n/d	200=415	n/d	200=275	n/d	n/d	n/d	n/d	n/d	n/d

n/a – not applicable

n/d – no data

Table 5 Cross Interference Table (pg.5)

Gas	PF ₃	SiH ₄	Si	SiF ₄	SO ₂	C ₄ H ₆ S	C ₄ H ₆ S	C ₆ H ₅ CH ₃	WF ₆	C ₄ H ₆ O ₂	C ₂ H ₃ CL	C ₂ H ₅ SH	C ₆ H ₅ CH ₃
C ₂ H ₃ O	n/d	n/d	n/d	n/d	n/d	n/d	40=45	n/d	n/d	40=200	40=200	n/d	40=55
C ₃ H ₃ N	n/d	n/d	n/d	n/d	n/d	n/d	75=45	n/d	n/d	75=200	75=200	n/d	75=55
NH ₃	n/d	n/d	n/d	n/d	5=-0.5	n/d	n/d	n/d	n/d	n/d	n/d	n/d	n/d
AsH ₃	n/d	1=0.56	n/d	n/d	2=0	n/d	n/d	n/d	n/d	n/d	n/d	n/d	n/d
Br ₂	n/d	n/d	n/d	n/d	5=-0.1	n/d	n/d	n/d	n/d	n/d	n/d	n/d	n/d
C ₄ H ₆	n/d	n/d	n/d	n/d	n/d	n/d	170=45	n/d	n/d	170=200	170=200	n/d	170=55
CS ₂	n/d	n/d	n/d	n/d	n/d	n/d	140=45	n/d	n/d	140=200	140=200	n/d	140=55
CO	n/d	n/d	n/d	n/d	5=0	n/d	n/d	n/d	n/d	n/d	n/d	n/d	n/d
Cl ₂	n/d	n/d	n/d	n/d	5=-0.05	n/d	n/d	n/d	n/d	n/d	n/d	n/d	n/d
ClO ₂ (>10ppm)	n/d	n/d	n/d	n/d	5=-0.016	n/d	n/d	n/d	n/d	n/d	n/d	n/d	n/d
ClO ₂ (=10ppm)	n/d	n/d	n/d	n/d	n/d	n/d	n/d	n/d	n/d	n/d	n/d	n/d	n/d
B ₂ H ₆	n/d	1=0.72	n/d	n/d	2=0	n/d	n/d	n/d	n/d	n/d	n/d	n/d	n/d
C ₃ H ₅ OCl	n/d	n/d	n/d	n/d	n/d	n/d	50=45	n/d	n/d	50=200	50=200	n/d	50=55
C ₂ H ₅ OH	n/d	n/d	n/d	n/d	n/d	n/d	180=45	n/d	n/d	180=200	180=200	n/d	180=55
C ₂ H ₅ SH	n/d	n/d	n/d	n/d	5=<3	n/d	n/d	n/d	n/d	n/d	n/d	n/a	n/d
C ₂ H ₄	n/d	n/d	n/d	n/d	n/d	n/d	220=45	n/d	n/d	220=200	220=200	n/d	220=55
F ₂	n/d	n/d	n/d	n/d	2=0	n/d	n/d	n/d	n/d	n/d	n/d	n/d	n/d
GeH ₄	n/d	1=1	n/d	n/d	2=0	n/d	n/d	n/d	n/d	n/d	n/d	n/d	n/d
N ₂ H ₄	n/d	n/d	n/d	n/d	2=0	n/d	n/d	n/d	n/d	n/d	n/d	n/d	n/d
HBr	n/d	n/d	n/d	n/d	5=2.5	n/d	n/d	n/d	n/d	n/d	n/d	n/d	n/d
HCl	n/d	n/d	n/d	n/d	5=2.5	n/d	n/d	n/d	n/d	n/d	n/d	n/d	n/d
HCN	n/d	n/d	n/d	n/d	2=0	n/d	n/d	n/d	n/d	n/d	n/d	n/d	n/d
HF	yes n/d	n/d	n/d	3=4(theory)	yes n/d	n/d	n/d	n/d	yes n/d	n/d	n/d	n/d	n/d
H ₂ S	n/d	n/d	n/d	n/d	5=<1	n/d	n/d	n/d	n/d	n/d	n/d	3=1	n/d
CH ₃ OH	n/d	n/d	n/d	n/d	n/d	n/d	415=45	n/d	n/d	415=200	415=200	n/d	413=55
CH ₃ SH	n/d	n/d	n/d	n/d	5=<2	n/d	n/d	n/d	n/d	n/d	n/d	2=1	n/d
NO	n/d	n/d	n/d	n/d	5=0	n/d	n/d	n/d	n/d	n/d	n/d	n/d	n/d
NO ₂	n/d	n/d	n/d	n/d	5=-0.025	n/d	n/d	n/d	n/d	n/d	n/d	n/d	n/d
O ₃	n/d	1=0.015	n/d	n/d	2=0	n/d	n/d	n/d	n/d	n/d	n/d	n/d	n/d
COCl ₂	n/d	n/d	n/d	n/d	2=0	n/d	n/d	n/d	n/d	n/d	n/d	n/d	n/d
PH ₃	n/d	1=0.56	n/d	n/d	2=0	n/d	n/d	n/d	n/d	n/d	n/d	n/d	n/d
SiH ₄	n/d	n/a	n/d	n/d	2=0	n/d	n/d	n/d	n/d	n/d	n/d	n/d	n/d
SO ₂	n/d	n/d	n/d	n/d	n/a	n/d	n/d	n/d	n/d	n/d	n/d	n/d	n/d
C ₄ H ₆ O ₂	n/d	n/d	n/d	n/d	n/d	n/d	200=45	n/d	n/d	n/a	200=200	n/d	200=55
C ₂ H ₃ Cl	n/d	n/d	n/d	n/d	n/d	n/d	200=45	n/d	n/d	200=200	n/a	n/d	200=55

n/a – not applicable

n/d – no data

9.4 Spare Parts, Sensor Accessories, Calibration Equipment

Part Number	Spare Parts
92C-XX0200-YYY	CXT-DM Intelligent Transmitter Module for Toxic Gas Sensors (where xx=Gas Code, and YYY=Range)
371-XXXX00-YYY	Replacement Plug-in sensor (Refer to Table 3 Sensor Specific Data)
500-005180-100	CXT Smart Battery Terminal Board
976-0BP303-012	Plug-in Battery Pack 12V 2200mAh (Rechargeable)
976-0BP303-290	Plug-In Battery Pack 12V 2900mAh (Rechargeable)
360-026500-000	Lithium Primary 3.6V 'C' size battery (non-rechargeable)
360-TL5930-000	Battery, Lithium 3.6V 'D'-size (non-rechargeable)
960-202200-000	Condensation prevention packet (For condulet, replace annually)
602-003870-000	Tri-C Size Battery Holder (for Lithium 3.6V non-rechargeable 'C' Size)
602-004402-000	D-Sized Battery Holder (for Lithium 3.6V non-rechargeable 'D' Size)
Sensor Accessories	
613-120000-700	Sensor Splash Guard with integral Cal Port
602-003803-000	CXT-DM Splashguard Adapter Assembly
602-003803-200	CXT-DM H2S Splashguard Adapter Assembly (For H2S Only)
943-002273-000	Harsh Environment Sensor Guard
327-000000-000	Programming Magnet
Calibration Accessories	
943-000006-132	Threaded Calibration Adapter
943-000000-000	Calibration Wind Guard
943-01747-T05	Calibration Adapter for highly reactive gases
943-050000-132	Span Gas Kit: Includes calibration adapter, span gas humidifier, 500cc/min fixed flow regulator, and carrying case. (Not including gas).
943-050000-HRG	Highly Reactive Gas Span Gas Kit (Used for NH ₃ , Cl ₂ , HCl, HBr, etc.)
See Teledyne	Span Gases – various
943-05AM00-000	500 cc/min Fixed Flow Regulator for span gas bottle
Optional Accessories	
897-850800-010	NEMA 7 Aluminum Condulet Base
897-850400-010	NEMA 7 Aluminum Condulet Solid Cover
897-850500-010	NEMA 7 Aluminum Condulet w/Window Cover
897-860401-316	316SS Mini Condulet Extended Cover
897-860800-316	316SS Mini Condulet base
960-202200-000	Condensation prevention packet (For condulet, replace annually)
943-004365-000	Wireless Sensor Mounting Plate (for use with Standard Al condulet)
500-005180-100	CXT Smart Battery Terminal Board
303-734231-000	Insertion tool, CAGE Clamp Connector
980-PRSM33-xxM	External Power Cable (where 'xx' is the cable length in meters)

10.Revision Log

Revision	Date	Changes made	Approval
0.0	03/31/12	Release	LU
0.1	12/04/12	Adding note requiring removal of sensor assembly to non-hazardous location to install or replace batteries	BM
1.2	2/21/13	Updated spare parts list, drawings	LU
1.3	9/30/13	Added section 2.1 Hazardous Location Guidelines	BM
1.4	01/20/14	Add Calibration Wind Guard to Calibration Procedures	BM
1.5	02/10/14	Add detail to battery installation	BM
1.6	05/29/14	Updated Approval Label	BM
1.7	09/08/14	Updated Approval Label	BM
1.8	11/24/14	Added CXT w/Strobe	LU
2.0	12/08/15	Updated to add D Cell, remove Group B gases	MM
2.1	12/10/19	Updated Company Information	MM
2.2	10/26/20	Updated approvals label, updated company address	KM
2.3	03/08/22	Removed labels and Updated certification references	KM

sales@norrscope.com