

GMS H₂S Detection Head 0-100ppm GMI Part No. 59374

Gas Type:	Hydrogen Sulphide
Range:	0-100 PPM (Parts Per Million)
Size:	38.5mm x 90mm
Thread Connection:	20mm standard, others as required
Material:	EN 316 Stainless Steel or 1802 Stainless Steel
Connections:	Red – N.C. Yellow – Signal/Supply Blue – 0v
Output Signal:	4-20 mA. Linear
Supply Voltage:	24 Vdc \pm 10%
Operating Life:	24 months in air at STP
Warranty Life:	12 months
Warm-up Time:	5 minutes
Temperature Range:	-10°C to +40°C as standard
Pressure Range:	Atmospheric \pm 10%
Relative Humidity:	15 to 90% non condensing
Repeatability (typical):	+ / -2% of reading
Zero Stability:	+ / -1% FSD (Full Scale Deflection)
Response Time:	Typically 25 secs to T90 Typically 12 secs to T50
Certification:	Ex II 2 GD Eex d IIc T6



Gas Measurement Instruments Ltd



Dimensions:

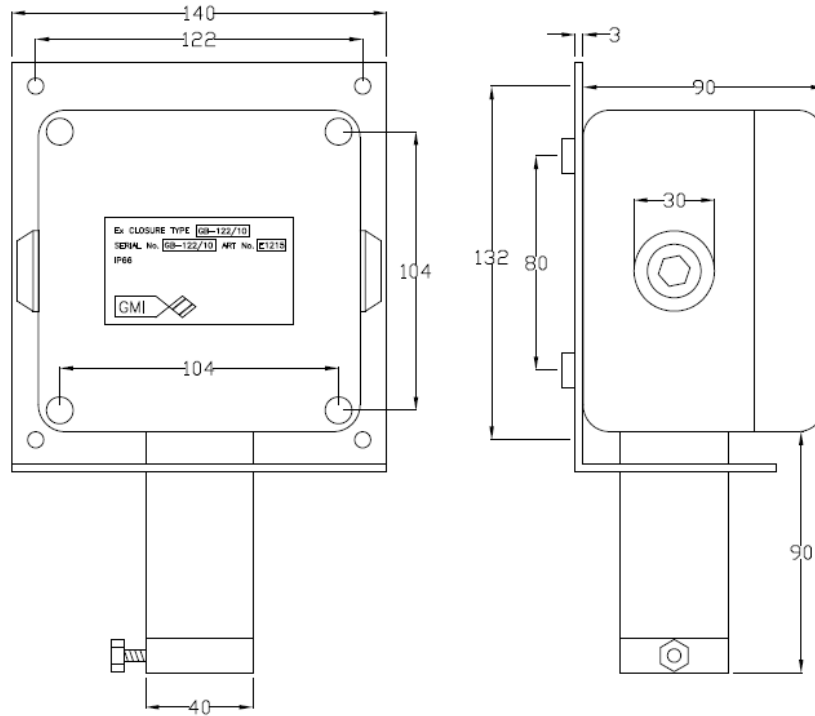

FRONT

SIDE

sales@norrscope.com