

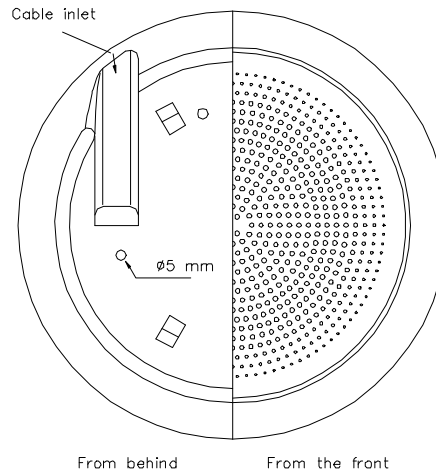

DNH

BLC-550(T)

ISO 9001 CERTIFIED

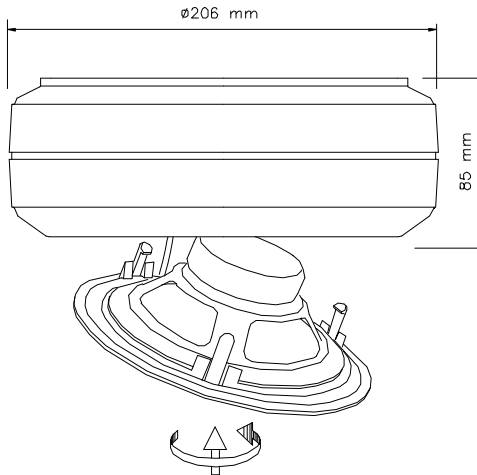

CIRCUIT DIAGRAM

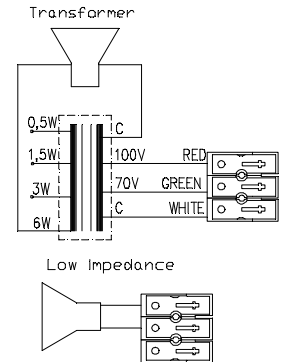

70/100 Volt combined transformer	
Primary connections	
White : Green	70 V
White : Red	100 V
Secondary nominal tapings	
C : 6W	6,0 W
C : 3W	3,0 W
C : 1,5W	1,5 W
C : 0,5W	0,5 W

Sound pressure levels at 1W/1m with P5/15T

SPL vs Freq

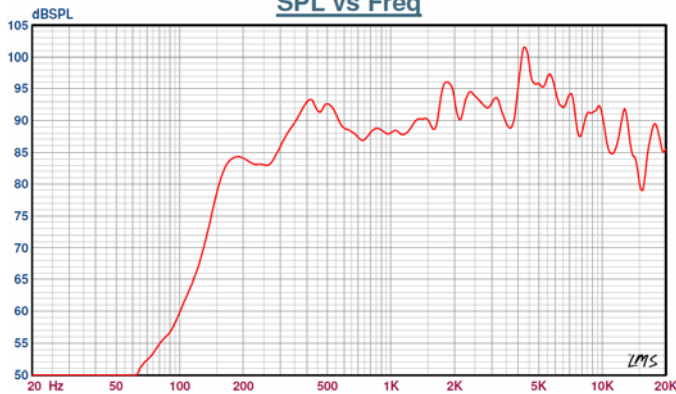

Specifications

Material / Color	ABS / RAL 9010
Mounting	Screws (max ø5mm)
Termination	Spring clamp
Weight w/transformer	0,93 kg
IP-rating	NA
Max. / min. amb. temp	90°C / -20°C
Rated / max. power	6 W / 6 W
SPL 1W/1m	90 dB
SPL rated power	97 dB
Effective freq. range	140 – 20000 Hz
Dispersion (-6dB) 1kHz / 4kHz	150° / 50°
Directivity factor, Q	NA
Options	Impedances, colors, labels

Installation, Operation and Maintenance Procedures

- Open the loudspeaker by turning the grill counter clockwise.
- Lead cable through cable inlet, connect to terminal (70V or 100V) and select required tapping on transformer.
- Screw the cabinet to the wall or ceiling with 4 screws.
- Screw the loudspeaker front gently clockwise into fixed position
- For optimum performance, always use the correct voltage / power and operate within the frequency limits as stated.
- Do not open loudspeaker when energized.
- This loudspeaker is supplied with a 2 year warranty against defective workmanship.

DNH reserves the right to alter specifications without notice

