

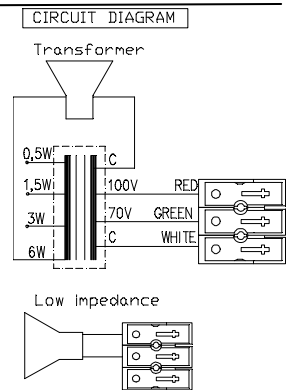

DNH

BKF-560CR(T)

ISO 9001 CERTIFIED

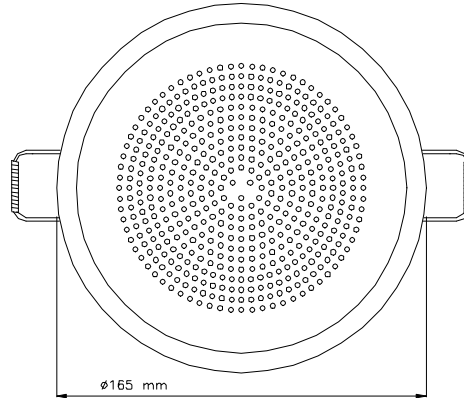
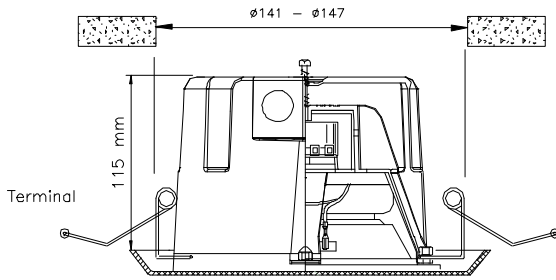

70/100 Volt combined transformer Primary connections	
White : Green	70 V
White : Red	100 V
Secondary nominal tapings	
C : 6W	6,0 W
C : 3W	3,0 W
C : 1,5W	1,5 W
C : 0,5W	0,5 W

Sound pressure levels at 1W/1m w/P-5/15T



Specifications

Material / Color	Aluminum / RAL9010
Plastic dust box	UL94-V0
Mounting	Springs
Termination	Spring clamps
Weight	0,74 kg
IP-rating	42
Max. / min. amb. temp	90°C / -20°C
Rated / max. power	6 W / 15 W
SPL 1W/1m	90 dB
SPL rated power	97 dB
Effective freq. range	200 – 15000 Hz
Dispersion (-6dB) 1kHz / 4kHz	170° / 60°
Options	Impedances, colors, labels

Installation, Operation and Maintenance Procedures

- Remove box by 1 screw, lead cable trough cable gland, connect to terminal (70V or 100V) and select required tapping in to the transformer.
- Install box by 1 screw to loudspeaker and mount the complete loudspeaker by bending back 2 springs.
- For optimum performance, always use the correct voltage / power and operate within the frequency limits as stated.
- Do not open loudspeaker when energized.
- This loudspeaker is supplied with a 2 year warranty against defective workmanship.

DNH reserves the right to alter specifications without notice

