

# Operating Manual

## MultiXplo and MultiTox Detectors



DG-TX7-X (Catalytic)

DG-TT7-K (Catharometer)



## Note

This manual must be carefully read by those who are or will be responsible for the operation or maintenance of this product. The product may not perform as designed if not used or maintained in accordance with the manufacturer's instructions.

The warranty made by Simtronics with respect to the product is voided if the product is not used and maintained as described in this manual.

Please read the general warnings in chapter 9.

© Simtronics SAS, all rights reserved.

1. Product description .....	6
1.1. Application Fields .....	6
1.2. DG-TX7-X .....	6
1.3. DG-TT7-K .....	7
1.4. Technical specifications .....	8
1.5. Detection Cartridge .....	9
1.6. Wireless Configuration Tool .....	9
1.7. Product Code .....	10
2. Technical features .....	12
3. Performances .....	14
4. Installation .....	16
4.1. Positioning .....	16
4.2. Assembly .....	16
4.3. Electric Connection .....	19
4.4. Detection cartridge .....	25
5. Commissioning .....	26
5.1. Visual inspection .....	26
5.2. Power-up .....	26
5.3. Operational tests .....	26
6. Operation .....	27
6.1. Environmental conditions .....	27
6.2. Inhibition .....	27
6.3. Signal current loop .....	28
6.4. Alarm indication .....	28
6.5. Display indication .....	29
6.6. Wireless communication tool TLU600 .....	30
6.7. Information menu [INFO] .....	33
6.8. Adjustment menu [ADJT] .....	34
6.9. Maintenance menu [MAIN] .....	39
6.10. Ambiguity function in combustible gas detector smart sensors .....	40
7. HART communication .....	41
8. Maintenance .....	42
8.1. Periodic maintenance .....	42
8.2. List of main faults .....	43
8.3. Replacing the cartridge .....	44
8.4. Replacing the complete detector .....	44
9. Warnings .....	45

---

9.1.	Safety.....	45
9.2.	Ownership and confidentiality.....	45
10.	Warranty.....	45
11.	Declaration of conformity .....	46
11.1.	Product standards .....	46
11.2.	Approvals .....	46
11.3.	Marking.....	47
12.	Accessories and spare parts .....	48
12.1.	Accessories.....	48
12.2.	Spare parts .....	50
12.3.	Gas table codes & range table codes .....	51
13.	Conformity certificate .....	54
14.	Contact details .....	59

## 1. PRODUCT DESCRIPTION

The DG-TX7-X is designed to monitor explosions risks induced by the presence of flammable gases or vapours (hydrogen, hydrocarbons, alcohol, etc.).

The DG-TT7-K is designed to monitor the gas concentration in %vol. induced by the presence of some special gases or vapours (hydrogen, helium, carbon dioxide, etc.).

The detector can be connected directly to a large range of traditional controllers or Programmable Logic Controllers (PLC).

The DG-TX7-X and the DG-TT7-K can be fully configured using the portable communication terminal (TLU600), providing flexibility to the user.

Thus, the calibration and the maintenance operations can be undertaken by a single operator.

The MultiXplo and MultiTox are also available for use in an addressable network system with distributed intelligence, SYNTEL. For more information, please refer to the Syntel module interface operating manual.

### 1.1. Application Fields

The DG-TX7-X and the DG-TT7-K are suitable for indoor and outdoor uses and offer a fast response time. Typical applications include:

- Storage and use of combustible/flammable gases and vapours(DG-TX7-X),
- Monitoring of processes with flammable products
- Hydrogen detection in inert atmosphere and in high concentration (DG-TT7-K),
- Chemical and petrochemical plants
- Pharmaceutical industry
- LNG/LPG
- Oil and gas facilities



### 1.2. DG-TX7-X

Detectors are calibrated on 100% LEL (Lower Explosive Limit) of a particular gas or vapour.

The DG-TX7-X is a MultiXplo detector based on a thermo-catalytic oxidation transducer, which requires oxygen to function properly.

In the event of a long period without oxygen, the measurement will no longer be representative of the concentration of gases or vapours.

The characteristics of the device can also be altered by the presence of certain catalyst poisons such as silicone fumes, vapours of organometallic compounds and, to some extent by halogenated compounds.

### 1.3. DG-TT7-K

The DG-TT7-K is a MultiTox detector, based on catharometric transducer. Its measurement range is usually expressed in terms of %vol. relative to a particular gas (for example 5%vol. H<sub>2</sub>, 5%vol. He...).

The DG-TT7-K measurement principle is based on the heat exchange between a heated filament and a "cold" separation. The effectiveness of the exchange between those two elements depends, in particular, of the value of the thermal conductivity of the mixture which separate them.

This measurement principle is very stable, and able to operate with high gas concentrations.

In this configuration, the presence of oxygen is not essential, and catalytic poisoning is not an issue.

## 1.4. Technical specifications

Each detector is constructed as follows:

- A wall-mounted support secured by three screws and including cable gland (M20) (optional). There are 2 standard entries and an optional one.
- A stainless steel explosion-proof housing containing:
  - A set of tropicalized electronic cards
  - A display and infrared communication electronic card allowing the communication with the remote control (TLU600)
- A colour coded cartridge, yellow for combustible gas detectors (DG-TX7-X) and brown for catharometers (DG-TT7-K), located in the lower part of the detector.

This cartridge is connected to the detector's body by an open ring leaving the label visible.

A colored ring enables the identification of the device type at a larger distance.

- A metallic support cable (optional) connects the wall mounting support and the housing, making the maintenance easier.

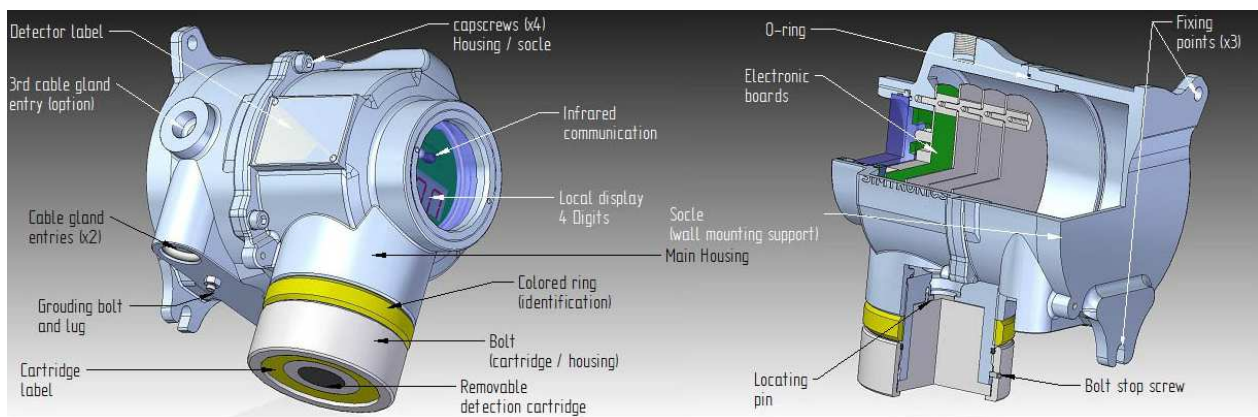

*Figure 1 : Layout Drawing*

(Outline drawing – see Figure 2)



**Note :** there are some special versions using stand alone Wheatstone ½ bridge probes as the SX202 type (product code :DG-TX7-\*\*DG-WXC-\*\*-000-0-\* -0)

**Such version will be called « External probe versions » in the rest of the document**



## 1.5. Detection Cartridge

Detection Cartridges are explosion proof designed.

They are common to all Simtronics MultiXplo and MultiTox-K products in order to reduce the number of spare parts.

- DG-RX7-X et DG-RT7-K: Network « Télécaptur » line
- DG-TX7-X et DG-TT7-K: « Télécaptur » line

For combustible gas detector's cartridges, if the difference between the storage temperature and the operating temperature does not exceed 20°C, the nominal characteristics are obtained after a few minutes. Otherwise, wait for the balancing thermal unit, about half an hour.

Catharometer cartridges (cartridges K) need to be in thermal balance with their environment to provide nominal performance. Thus, when the cartridges have been unpowered more than half-an-hour, a warm-up time is required when power is restored. The duration of warm-up is usually range from ½ hour to 4 hours, depending on the temperature difference between the cartridge and the ambient temperature.

The cartridge temperature information is available on the TLU.



**The cartridge must not be unplugged when the detector is powered.**

## 1.6. Wireless Configuration Tool

Information and status of the detector are available via the wireless configuration tool TLU600/610.

Configuration and tests are performed using this wireless configuration tool (IrDA protocol). This tool is common for all Simtronics MultiFlame, MultiXplo and MultiTox products.

The TLU600/610 provides access to devices that, otherwise, would require major logistic operations for maintenance or for configuration (calibration ...).

For more details, please refer to the wireless configuration tool operating manual.



**Some versions are equipped with the HART communication protocol, enabling acces to the same functions as the TLU(see §7)**

## 1.7. Product Code

Product codes are created from functional codes: **DG-<sup>\*\*</sup>7-<sup>\*\*\*</sup>\*\*\*-<sup>\*\*</sup>\*\*\*-<sup>\*\*</sup>\*\*\*-<sup>\*</sup>\*-<sup>\*</sup>\*-<sup>\*</sup>\***

Detector type													
T	X	7	30	DG	-X	X	H	-X	0	-00J	-0	-C	-0
<b>C<sup>**</sup></b>	Compact Sensor												
<b>T<sup>**</sup></b>	Télécapteur												
<b>R<sup>**</sup></b>	Network version												
<b>S<sup>**</sup></b>	Replacement cell												
<b>X<sup>**</sup></b>	Accessories												
Families													
<b>*T<sup>*</sup></b>	Toxic												
<b>*V<sup>*</sup></b>	Flame												
<b>*X<sup>*</sup></b>	Flammable gas												
<b>*0<sup>*</sup></b>	None												
Version													
<b>**6</b>	BT606 housing												
<b>**7</b>	BT10 housing												
Gas type													
<b>**</b>	Refer to gas matrix												
	Measurement range												
<b>**</b>	Refer to gas matrix												
Type													
XV	UVIR2												
XT	IR3												
XW	UV												
Detection range													
A0	Standard range												
B0	Long range												
Input Type													
<b>0<sup>**</sup></b>	Not used or flame												
<b>E<sup>**</sup></b>	Electrochemical												
<b>S<sup>**</sup></b>	Semi-conductor												
<b>K<sup>**</sup></b>	Catharometer												
<b>X<sup>**</sup></b>	Catalytic												
<b>M<sup>**</sup></b>	MECH												
<b>R<sup>**</sup></b>	TOR input												
<b>C<sup>**</sup></b>	Current input 0/22 mA												
<b>I<sup>**</sup></b>	Infrared												
<b>W<sup>**</sup></b>	½ Wheatstone bridge												
Variant													
<b>*A<sup>*</sup></b>	Aluminium												
<b>*X<sup>*</sup></b>	SS316												
Output Interface													
<b>**M</b>	1-2 mA protocol												
<b>**A</b>	0-22mA protocol (fault signalling in 0-4mA range)												
<b>**E</b>	4-20 mA protocol (Common fault signal 2 mA)												
<b>**H</b>	4 – 20 mA / 0-22 mA configurable & HART protocol												
<b>**C</b>	4 – 20 mA / 0-22 mA configurable												
<b>**W</b>	Wheatstone												
<b>**L</b>	LON												
<b>**X</b>	4 – 24 mA for compact explosimeter												

T	T	7	31	AF	-S	X	H	-C	0	-00J	-0	-C	-0
<b>Cartridges</b>													
DGi-TT7-O / Dmi-TT6-O													
Dgi-TT7-E / Dmi-TT6-E													
Dgi-TT7-O / Dmi-TT6-O													
DG-TT7-S / DM-TT6-S													
Half Wheatstone bridge probes													
DG-TT7-I / DM-TT6-I													
DG-TT7-I / DM-TT6-I													
<b>Semicond. Sensor type &amp; special configurations</b>													
*0 Not specified or standard													
*A 20													
*B 23													
*C 24													
*D 25													
*E 27													
*F 30 (become obsolete to release *R association)													
*M Special version MarED (TX6 and TV6 in type A only)													
Options *N Special version with ALRM LED not memorized (not in compliance with EN 54-10) (flame version only)													
*R With relay board for HW type D													
Customized versions *1 Customized EPR (special follow up, SP4M20) (DM and DMi only)													
*2													
<b>Configuration</b>													
000 Standard													
00A Absolutely no grease													
00B Special version MarED (old code) (TX6 and TV6 in type A only)													
00C Not EN 54-10 compliant version (not latched ALRM LED) (type A only)													
00D IRDA cap instead of display													
00E 0V not connected to housing ground on Tox type C													
00F TCM02 instead of IRDA cap													
00G Hydrocentrifugon paint (nuclear applications)													
00H Special paint : light grey (10A03 according to « British standards 4800/5252 »)													
00J Special paint : red (RAL 3001)													
Language													
0 Fr / GB													
F French													
E English													
P Portuguese													
C Chinese													
<b>Hardware version</b>													
A Type 63													
B Type 65													
C Type 67 (HART)													
D Type 69 (magnet)													
<b>Software version</b>													
0 Standard													

## 2. TECHNICAL FEATURES

### GENERAL

Type	Gas detector
DG-TX7-X	MultiXplo (catalytic gas detector)
DG-TT7-K	MultiTox (catharometer gas detector)
DG-RX7 or DG-RT7	Network detector
Calibration	Factory set, recommended test every 6 months

### OUTPUT SIGNALS

4-20mA loop signal	Type active (source) maximum load impedance 700Ω														
E version - « 4-20mA »	4-20mA with one fault level <table> <tr> <td>- 0% full scale</td> <td>4 mA</td> </tr> <tr> <td>- 100% full scale</td> <td>20 mA</td> </tr> <tr> <td>- 105% full scale</td> <td>20.8 mA</td> </tr> <tr> <td>- Ambiguity function</td> <td>21.7 mA (DM-TX6-X)</td> </tr> <tr> <td>- Fault or inhibition</td> <td>2 mA</td> </tr> </table>	- 0% full scale	4 mA	- 100% full scale	20 mA	- 105% full scale	20.8 mA	- Ambiguity function	21.7 mA (DM-TX6-X)	- Fault or inhibition	2 mA				
- 0% full scale	4 mA														
- 100% full scale	20 mA														
- 105% full scale	20.8 mA														
- Ambiguity function	21.7 mA (DM-TX6-X)														
- Fault or inhibition	2 mA														
A version - « 0-22mA »	4-20mA with several fault levels, for PLC and some recent control units <table> <tr> <td>- 0% full scale</td> <td>4 mA</td> </tr> <tr> <td>- 100% full scale</td> <td>20 mA</td> </tr> <tr> <td>- &gt;105% full scale</td> <td>20.8 mA</td> </tr> <tr> <td>- Ambiguity function</td> <td>21.7mA (DM-TX6-X)</td> </tr> <tr> <td>- Inhibition</td> <td>3.4 mA</td> </tr> <tr> <td>- Fault measure</td> <td>2.6 mA</td> </tr> <tr> <td>- Device fault (HW/SW)</td> <td>2.0 mA</td> </tr> </table>	- 0% full scale	4 mA	- 100% full scale	20 mA	- >105% full scale	20.8 mA	- Ambiguity function	21.7mA (DM-TX6-X)	- Inhibition	3.4 mA	- Fault measure	2.6 mA	- Device fault (HW/SW)	2.0 mA
- 0% full scale	4 mA														
- 100% full scale	20 mA														
- >105% full scale	20.8 mA														
- Ambiguity function	21.7mA (DM-TX6-X)														
- Inhibition	3.4 mA														
- Fault measure	2.6 mA														
- Device fault (HW/SW)	2.0 mA														
Output relays	2 x configurable relays max 1A / 30V <sub>AC/DC</sub>														
<b>ELECTRICAL</b>															
Power supply:	24VDC, (18 – 28 V DC versions DG-T#7) (18 – 30 V DC versions DG-R#7))														
Consumption:	2 W (typical), 5 W maximum (max brightness display)														
Wiring:	0,5mm <sup>2</sup> (20AWG)-1,5mm <sup>2</sup> (16AWG).														
MTBF:	123 000 h (Version DG-T#7 out of the sensing element)														

## ENVIRONNEMENT

Storage temperature	-40°C to +70°C (2 years in « clean » atmosphere)
Temperature range	-40°C to +60°C (except external probe versions) -20°C to +60°C (external probe versions)
Pressure	1013 Hpa ± 10%
Humidity	95% HR (non condensable)
Protection	IP66
RFI/EMI	EN 50270
Heating time (DG-TX7-X):	< 100 sec
Stabilisation time (DG-TX7-X):	< 190 sec

## PERFORMANCE (DG-TX7-X)

European	EN 60079-29-1 (except external probe versions)
----------	--

## EXPLOSION PROOF HOUSING

Material	stainless steel 316 L
Weight	4.0 kg stainless steel
ATEX/IECEX	 II 2 G / Ex d II C T6 Gb -40°C < Ta < + 65°C (except external probe versions) -20°C < Ta < + 60°C (external probe versions)
Dimensions	-20°C < Ta < + 60°C (external probe versions)

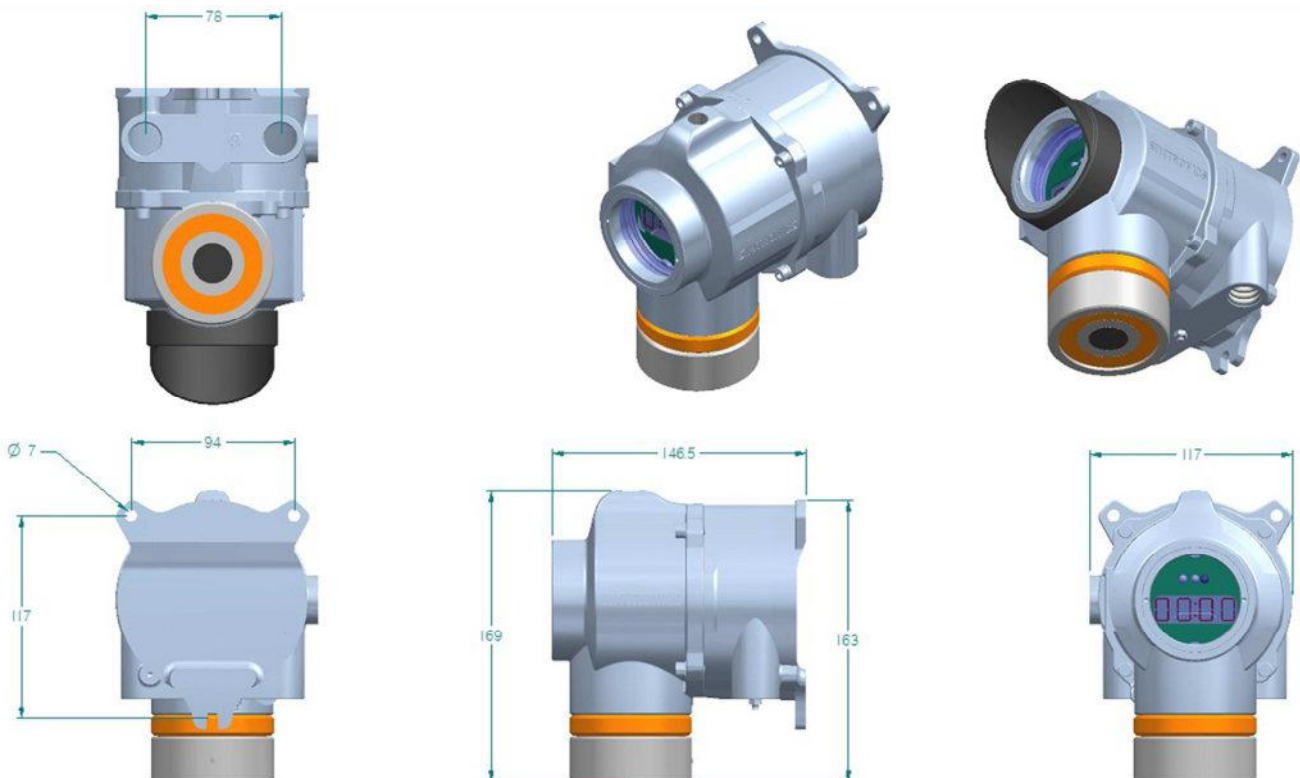

Figure 2: Outline drawing (mm)

(Version with SX202 : height dimensions = 190mm )

### 3. PERFORMANCES

Expected life time in standard conditions:

- >5 years for DG-TX7
- >10 years for DG-TT7-K

This lifetime can be reduced in case of exposure to dusty environments.



For catalytic version, some compounds are known to poison sensors. These include, organometallic, silicone and some halogenated compounds

PERFORMANCES	DG-TX7-X			DG-TT7-K		
	CH <sub>4</sub>	H <sub>2</sub>	C <sub>4</sub> H <sub>10</sub>	H <sub>2</sub>	CO <sub>2</sub>	He
Ranges	100 % L.E.L. (5.0 %vol)	100 % L.E.L. (4.0 %vol)	100 % L.E.L. (1.9 %vol)	5%vol 20%vol 100%vol	20%vol	5% vol 20% vol 100% vol
Relative sensibility	1.54 ①	1.60 ①	1.00 ①			
$\tau$ (0-90%) (sec)	< 15	< 10	< 20	< 10	< 30	< 10
Zero point stability ②	< 3	< 3	< 3	< 3	< 3	< 3
Sensibility drift ②	< 3	< 3	< 3	< 3	< 3	< 3
T° range (°C) ⑦	-40 / +60	-40 / +60	-40 / +60	-40 / +60	-40 / +60	-40 / +60
Temperature zero drift ② ③	< 2	< 2	< 2	< 3	< 5	< 3
Temperature sensitivity drift ② ③	< 3	< 3	< 3	< 3	< 5	< 3
Linearity ②	< 3	< 1	< 3	< 2	< 2	< 2
Repeatability ②	< 1	< 1	< 1	< 1	< 1	< 1
Expected service life ④	>5	>5	>5	10	10	10
Relative humidity (% HR)	0 – 95 % condensation free			15 – 95 % condensation free		
Pressure range	Pa±10%					
Cross sensitivity	All inflammable compounds ⑥			All gases with either very high or very low thermal conductivity		
Poisons	Silicon compounds, certain halogen compounds, and some organometallic compounds.			None		
Effect of O <sub>2</sub> – enriched or depleted atmospheres	15 % O <sub>2</sub> min.	10 % O <sub>2</sub> min.	15 % O <sub>2</sub> min.	None		
Biasing time ⑤	90 sec			120 sec		

- 
- ❶ Measured at 50% LEL of the considered gas
  - ❷ In % full scale
  - ❸ On the range: -10°C to +40°C.
  - ❹ (In years) Expected values based on “typical” site operating conditions without poison or corrosive compounds.

Lifetime can significantly vary (better or worse) depending on real site conditions.

- ❺ Measure available but full performance may require longer time. See Chapter 2.
- ❻ As soon as a gas or vapour is flammable, it is may be sensed by the combustible gas detector.

Sensitivity (regarding LEL range) and the response time depend on the compound. Basically, as the molecule size increase, the response time increase and the sensitivity decrease.

- ❼ For external probe versions, temperature range is limited to -20 / +60 °C

## 4. INSTALLATION

The detectors described in this manual are safety instruments intended to be installed in explosive atmospheres and have been designed in compliance with standards EN60079-0 and EN60079-1, EN 60079-29-1, CEI 60079-0 and CEI 60079-1.



Intervention in some sites may be subject to restrictions that we invite you to follow for your own safety and those of others.

### 4.1. Positioning

The detector must be positioned as close as possible to sources of potential leakages, taking into account airflows (e.g. upper and lower ventilation). The height is determined by the density of gas to detect.

Generally speaking, a detector will not be placed in front of an air inlet which brings clean air

This height may be adjusted to take into account the specific conditions which may interfere on the risk level (gas density, ambient temperature....)

### 4.2. Assembly

Use the two 7 mm diameter holes and the half slotted hole to secure the support.

It is highly recommended to install the support with cable-gland downward in order to avoid water infiltrations. In case of horizontal position, it is advised to make one or two loops with the cable at the entry of the cable-gland.

On stainless steel housings, plugs are sealed with Loctite. If the plugs are moved or removed, it must be sealed again, using Loctite or equivalent.

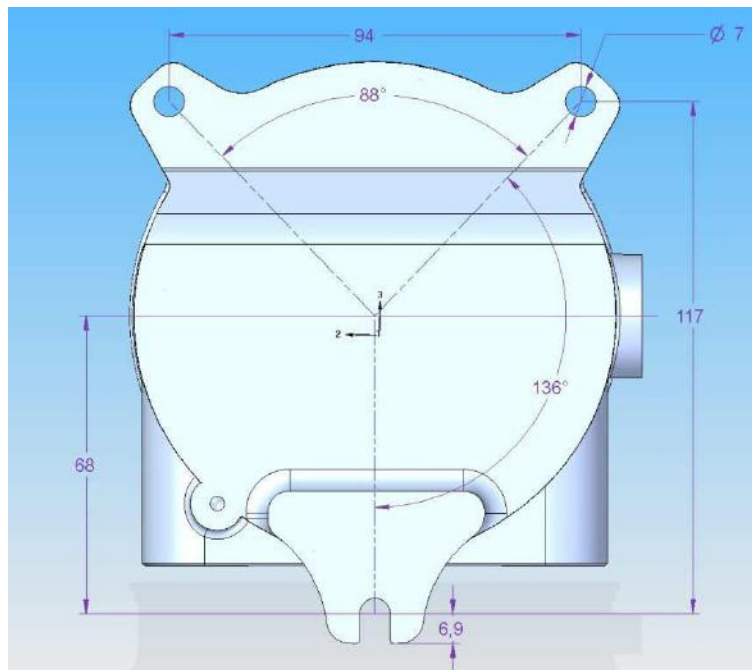

Figure 3: Drilling dimensions for support fixing.



### 4.2.1. Detector assembly

Check the presence of the O-ring on explosion proof seal, make sure that it is correctly greased and has no visible damage. Plug connectors to the base, as described in paragraph "Electric connection".

Fit the main housing on the base, placing the cable excess in the base. Put in place and tighten the four M5 screws with their grower rings.

It is possible to set up a suspension cable (not supplied) between the base and the housing (at the lower part) with two threaded holes (M4 x 6).

### 4.2.2. Cable's inputs (as an option)



**Connection cables must pass through a cable gland (Explosion Proof certified)**

For installation details, refer to the instructions provided by the manufacturer of the cable gland used.



**The unassigned cable glands entries must be blanked with explosion proof certified plugs (M20). They are glued with Loctite (type tubétanche 577) or equivalent compound. If a plug is moved or removed, it must be glued again with Loctite or an equivalent.**

### 4.2.3. Communication using the TLU 600

Communication elements are located above the display.



The orientation enables a communication with  $\frac{1}{2}$  horizontal angle about  $35^\circ$ ,  $\frac{1}{2}$  vertical-up angle about  $30^\circ$  and a vertical-down angle about  $50^\circ$

## 4.3. Electric Connection



**Never adjust electrical connections when detectors are powered. Maintenance must be undertaken by qualified staff. Observe safety site rules.**

The MultiXplo and MultiTox are sensors with standard current output 4-20mA or 0-22mA. The connection can be on 3 or 4 wires. The 4 wires configuration allows insulation between the signal and power loops.

In addition, two independent relays outputs can be connected directly to a controller or signal device.

We recommend using an armoured and shielded cable, type NF M 87 202, in accordance with the requirements for hazardous areas and NF C 15 100. Other cables can be used if they are compliant with the local regulations and standards.

The table below shows the maximum cable lengths in meter (ft) based on the wire cross section and the supply voltage.

Min. single wire cross section mm <sup>2</sup> /AWG	0.5 (20)	0.9 (18)	1.5 (16)
Supply voltage 24VDC / consumption power ≤ 2W	580 (1900)	1000 (3280)	1000 (3280)
Supply voltage 24VDC -10% / consumption power ≤ 2W	340 (1110)	600 (1960)	1000 (3280)
Supply voltage 24VDC / 2W < consumption power ≤ 3.5W	330 (1080)	580 (1900)	1000 (3280)
Supply voltage 24VDC -10% / 2W < consumption power ≤ 3.5W	200 (650)	340 (1110)	600 (1960)
Supply voltage 24VDC / 3.5W < consumption power ≤ 5W	230 (750)	400 (1310)	710 (2320)
Supply voltage 24VDC -10% / 3.5W < consumption power ≤ 5W	140 (450)	240 (780)	430 (1410)

NB : Those values are calculated considering the minimum supply voltage at 18VDC at the sensor level

### 4.3.1. Installation recommendation

This detector version is supplied in an electronic version **Type-C**. The terminal V- is isolated from the electric ground of the housing

The detector is supplied with a configurable current output type C (4-20 mA, factory configuration). But it can be modified in format 0-22 mA by the user, using one of the menus of the TLU 600.

Example: DG-**7**-\*\*\*\*-**C**-\*\*-\***C**-\*

This electronic Type C also allows the detector to get a HART output (as an option) superimposed to the output current. The current output format follows the same logic as the one described above but the product code contains an H:

Example: DG-**7**-\*\*\*\*-**H**-\*\*-\***C**-\*

That version also embeds two electrical connectors for the two relays.



### Terminal blocks

Point	JP12 & JP13	Description
1	T2	Relay 2
2	C2	Relay 2
3	T1	Relay 1
4	C1	Relay 1

Point	JP11	Description
1	V-	0 V
2	V+	+24VDC power supply
3	V+	+24VDC power supply loop (connected to point 2)
4	V-	0 V, Connected to point 1
5	L+	20mA Current loop: entry
6	L-	20mA Current loop: output

#### 4.3.2. Connection of the electrical ground braid

Use a shield connection clamp (not supplied) to connect the shielding of the cable to the electric ground of the housing (see § below).

#### 4.3.3. Grounding

A M4 screw passes through the body of the enclosure, enabling the electronic ground of the housing to be connected to the local ground.

It is recommended to use a yellow / green wire with a ring lug (minimum diameter 1.5 mm). The armour of the power cable is normally connected to the ground of the detector, but it may depend on site practices.



#### 4.3.4. 3-wires connection (source)

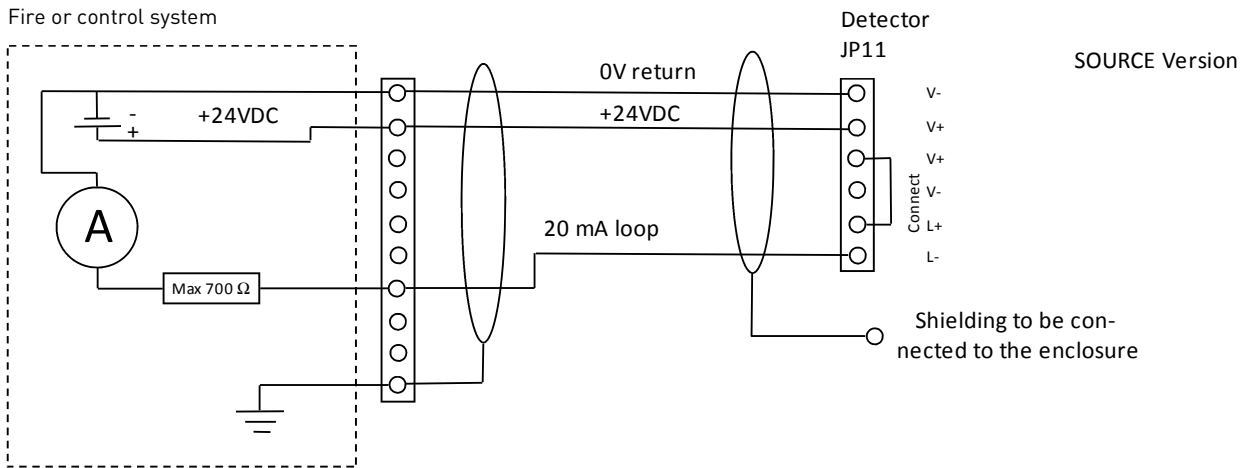

For a standard 3-wires connection, the 20mA current loop must be supplied with 24 V at terminal L+. To proceed, connect the 3 (V +) and 5 (L +) terminals at the terminal block level of the device.

#### 4.3.5. 3-wires connection (Sink)

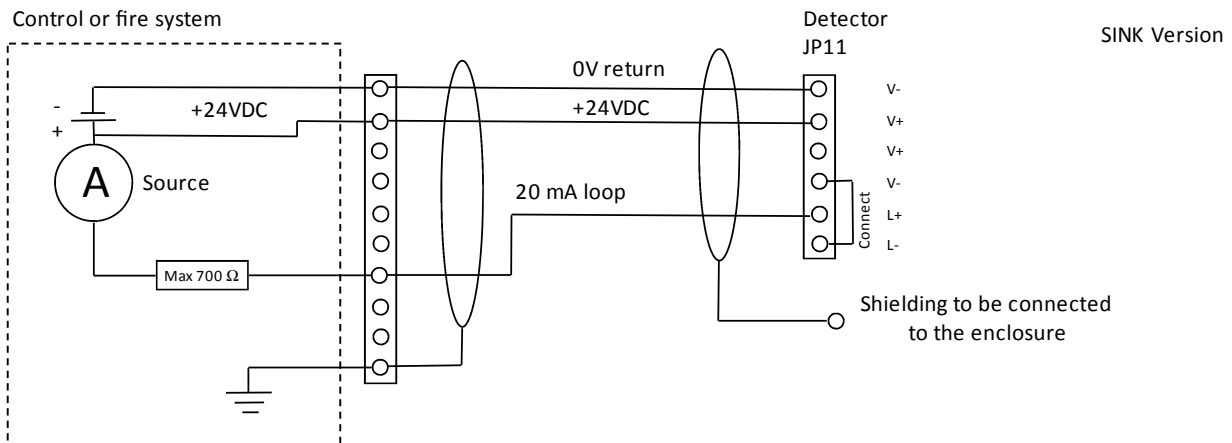

For a standard 3-wires connection in sink mode, the 20mA current loop must be supplied with a PLC. The current return must be connected to the 0V at the level of the L- terminal. To proceed, please connect the 4 (V-) and 6 (L-) terminals at the terminal block level of the device.

### 4-wires connection (isolated power)

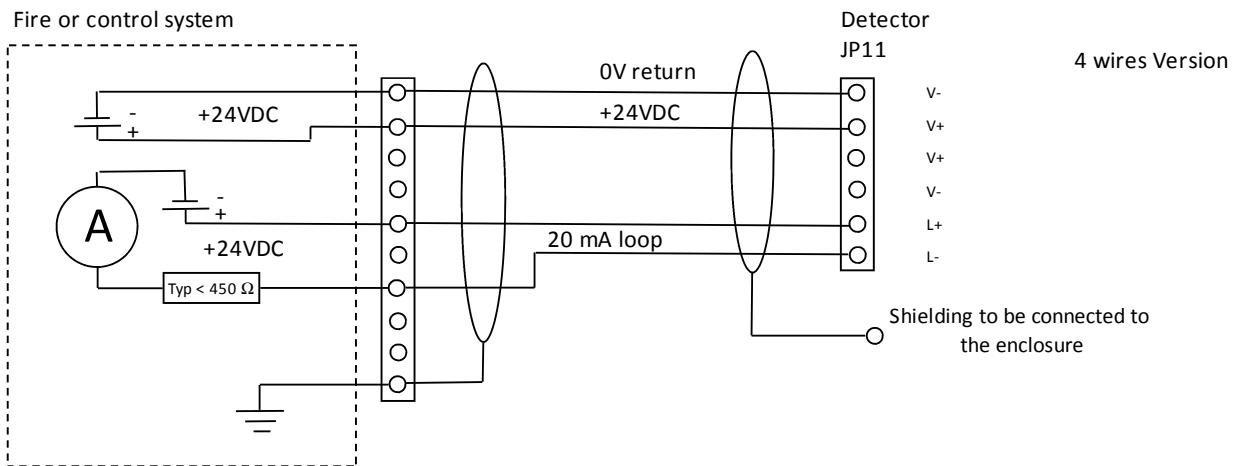

When using a 4 wires connection, the current loop is provided by the input module or PLC. The loop (L + and L-) is optically isolated from the detector. 4-20mA or 0-22mA input module of the PLC has to power up the current loop with, at least 8V at the terminal level, for 22 mA. This reduces the resistance of the loop as defined in the relationship below.

$$R_{maxi} = \frac{\text{Powersupply voltage} - 8V}{22mA}$$

In practice, the total loop resistance should not exceed 450 Ω with a voltage >18Vdc

### 4.3.6. Relay

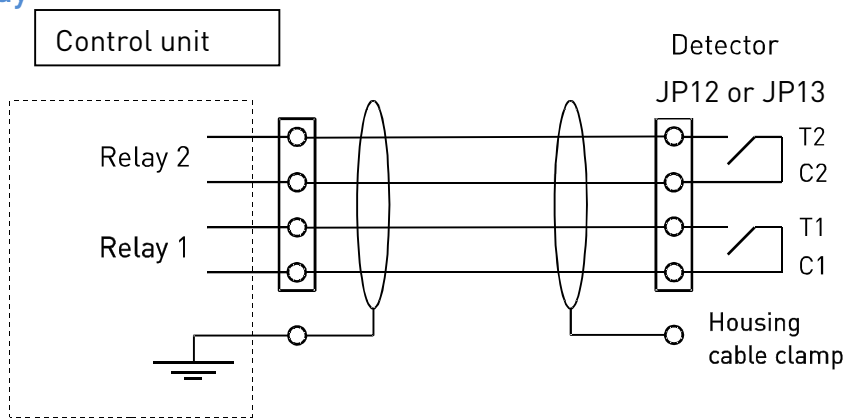

The two relays can be configured normally closed or normally open. If normally open, the relays are opened when they are not powered (power loss).

The circuits' relays are isolated from each other and from other parts of the detector. The two relays can be activated on one or more states of the detector, as shown below:

Activated on	Relay 1 "Alarm"	Relay 2 "Fault"	Comments
Alarm	Normally Open		4 possible levels
Fault		Normally closed	2 types of fault
Inhibition		Normally closed	2 types of inhibition

With an electronic configuration type C, two terminal blocks are available. The pins are connected to each other, from a terminal to the other one.

### 4.3.7. Syntel connection

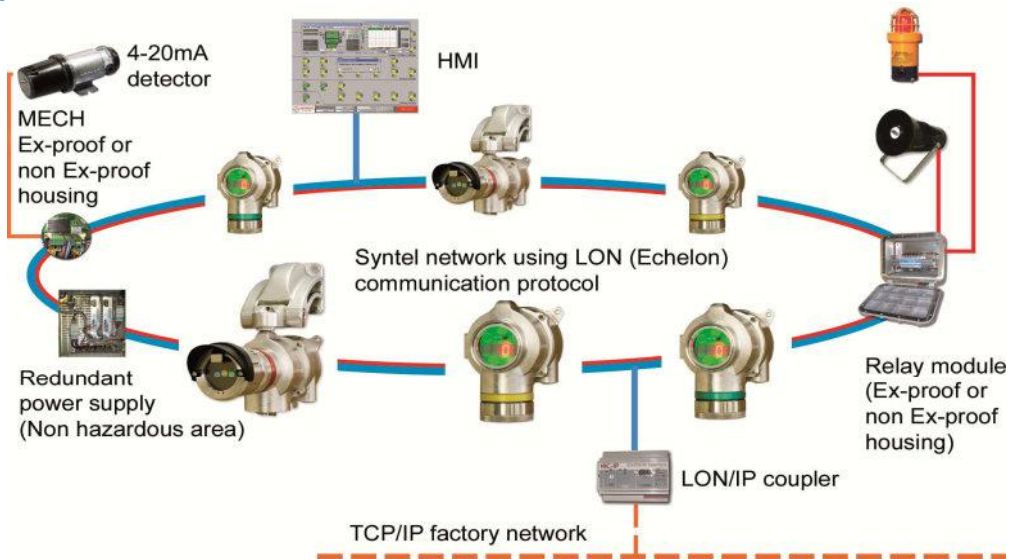

In this network version, an electronic board is inserted in the detector body and is used for electric connection.

Connecting the ground terminal should be performed thanks to 3-wire shielded cables.

The connection of power supply wires (4 on side A and 4 on side B).

- Two red wires on V +: +24 V
- Two white wires on V -: 0 V

Connection of the media wires (2 on side A and 2 on side B)

- A red wire on one of the N
- A white wire on the other N (no specific edge)

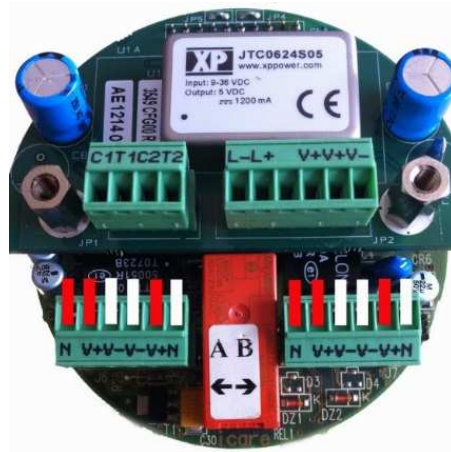

Figure 4: Connecting drawing of the network versions



For more detail, thanks to refer to the operating manual NOSP 15251

### 4.3.8. 0-22mA input connection

In one of its inputs type, type (C): **DG-\*\*7-\*\*\*\*-C\*\*-\*\_\*-\*\*\*-\*\_\*-\*** the device enables to use a 0-22mA input from another sensor.

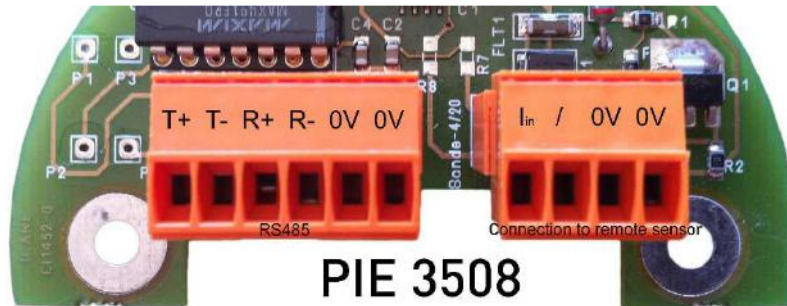

In that case, an input of the cable gland or an accessory in replacement of the cartridge enables the connection between the hosted sensor and the device.

In order to operate this analog input, an additional electronic card (PIE 3508 or PIE 3509) is added above the numeric card



The hosted sensor **NEEDS** to get its own power



Using this board leads to a connection between 0V from power supply and housing ground

### 4.3.9. Half bridge explosimeter input

It is possible to configure a device with an Ex05 remote explosimeter probe or a SX202 as an external probe. In the below configuration, the input is of type Combustible Gas Detector (X) and the cartridge is of type E.

With half bridge explosimeter probe (SX202, MTHX), the device is designed as:

**DG-\*\*7-\*\*\*\*-X\*\*-E\*-\*\_\*-\*\*\*-\*\_\*-\***

With the external half bridge explosimeter detector (EX05, EX09), the device is designed as:

**DG-\*\*7-\*\*\*\*-W\*\*-#\*-\*\_\*-\*\*\*-\*\_\*-\***

In that case, an input of the cable gland or an accessory in replacement of the cartridge enables the connection between the hosted sensor and the device.

In order to operate this analog input, an additional electronic card (PIE3521) is added above the numeric card.

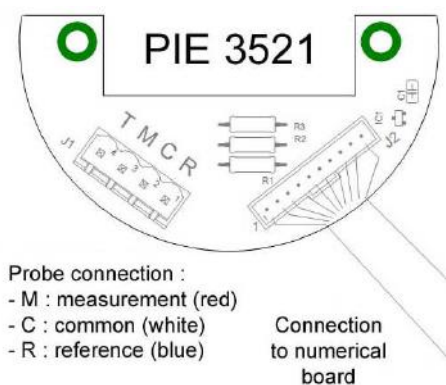

Using this board leads to a connection between 0V from power supply and housing ground



## 4.4. Detection cartridge

The cartridge is separated from the detector to enable its replacement. Its dismantling is extremely easy and does not need to touch the rest of the unit.



**Caution during the assembly and the disassembly of the cartridge on the detector:**

- Slide the positioning pin of the cartridge into the corresponding hole in the housing (at the bottom of the receiver).
- Take care to not damage the cartridge connector when tightening the two parts.
- This operation imperatively requires power to be off



Loosen the locking screw on the side of the nut (see Figure 1), then unscrew the nut, along the first part of the thread. With the nut, pull on the cartridge to remove it and then unscrew the cartridge from the nut.

Cartridges have an identification colour ring (see §1.5).

Insert a new cartridge of the same colour into the case respecting the position defined by the centring pin, screw the nut until it stops ensuring the presence of O-ring. Then, tighten the locking screw.

Switch on the device in order to make the calibration of the new cartridge and the zero adjustment.

## 5. COMMISSIONING

### 5.1. Visual inspection

Make certain that all the operations of the “Installation” chapter have been achieved correctly.

Pay particular attention on installation conformity, check the cables entry, the presence of O-rings, and the connection of the cartridge.

- The label on the smart sensor indicates the type of detector, the type of gas and the range for which the instrument has been calibrated
- The cartridge colour must correspond to the type of detector:
  - Yellow for combustible gas
  - Brown for catharometer

### 5.2. Power-up

The detector is powered through the multichannel detection unit or the Programmable Logic Controller.

- The backlight turns violet
- The display (red) appears. It displays, among other information, the INH which indicates the start-up inhibition and the warming up remaining time in *min* and *sec*.
- After this warming up time, the backlight turns green and the current concentration is displayed.

### 5.3. Operational tests

All MultiXplo / MultiTox detectors are delivered set and tested. Some additional tests are necessary to check the good working of the loop. Please make sure to have all authorizations needed before running the following operations:

- Check the states/information using the wireless configuration tool (TLU),
- Check the alarm levels
- Zero point:  
If there are no polluting gases or, if necessary, by injecting clean air at 30 l/h using the calibration kit equipped with an air cylinder
- Sensitivity:  
By injecting a suitable gas mixture at 30 l/h using the calibration kit
- Check the servo controls

## 6. OPERATION

### 6.1. Environmental conditions

The lifetime of the catalytic cartridge depends on the operating environment related to certain pollutants.

Take care to avoid exposures to some vapours products as silicone (vapours of some paintings, some seals ...), halogenated products (molecules containing one atom of chlorine, fluorine, bromine) or as sulphur ones (H<sub>2</sub>S...).

### 6.2. Inhibition

Maintenance Inhibition is temporary. It appears during power up and maintenance phases. Inhibition stops automatically when the operator get out of the maintenance menus or 10 minutes after the end of communication with the TLU.

Maintenance inhibition can be configured in "frozen" mode (Factory setting) or in "free" mode.

- In "frozen" mode, outputs (current and relay) remain in their previous state. For example, if the device indicated a fault (2.0 mA), this state would be maintained during the inhibition.
- If the unit is configured in "free" inhibition mode, the output current will be on the same level as for the permanent inhibition

The permanent inhibition is activated by an order issued by the TLU when an operation is performed at or around the device, or when the operator wants to inhibit a faulty device. The permanent inhibition must be removed by an operator's deliberate action using the TLU.

As for the maintenance inhibition, this special mode is leading to a violet colour from the backlight.

### 6.3. Signal current loop

State	"4-20" [mA]	"0-22" [mA]	Display	TLU state
Line fault	0.0	0.0		
Configuration fault	2.0	2.0	DEF & yellow Backlight	DEF
Detector fault (electronic)	2.0	2.0	DEF & yellow Backlight	DEF
Measure fault	2.0	2.6	DEF & yellow Backlight	DEF
Start inhibition	2.0	3.4	INH & violet Backlight & cycle**	Warming-up remaining time including power up
Permanent inhibition	2.0	3.4	INH & violet Backlight & cycle**	INH
Maintenance inhibition Fixed configuration (fault) / ("free mode") *	Previous value/ (2.0)	Previous value/ (3.4)	INH & violet Backlight & cycle**	INH
Alarm verification	21.7	21.7	DEF & red Backlight	100% - DOUT DEF
0% of full scale	4.0	4.0	Cycle** & green Backlight 0	No detection No alarm
25% of full scale	8.0	8.0	Cycle** AL1 or AL2 if reached	Alarm if level exceeded
50% of full scale	12.0	12.0	Cycle** AL1 or AL2 if reached	Alarm if level exceeded
75% of full scale	16.0	16.0	Cycle** AL1 or AL2 if reached	Alarm if level exceeded
100% of full scale	20.0	20.0	Cycle**	Alarm
105% of full scale	20.8	20.8	& red Backlight 100 - AL2	Alarm

(\* ) Maintenance inhibition may be available in frozen or free mode.

(\*\* ) The cycle is the display sequence of the concentration, unit of measure and target gas.

### 6.4. Alarm indication

When an alarm status is confirmed, the backlight turns red. Moreover, the display indicates the alarm level and the current concentration.

The remaining information which is usually recorded in the display cycle are not provided anymore, in order to keep the detection and current alarm level as a priority.

If the alarm memorization is enabled, the backlight light remains red and the alarm indication appears in the display cycle until the alarm is acknowledged with the TLU or the detector is powered off, then powered on again.

If the alarm memorization is disabled, the backlight turns green when the alarm fades.

## 6.5. Display indication

The 4 Digits display provides several information, depending on the state of the device:

### STARTING:

- Display cycle : concentration and measuring scale (25 then % then LIE then CH4, for example)
- Alternately indicates the inhibition mode and the warming up remaining time

### NORMAL OPERATING MODE:

The digital readout provides the following information:

- Concentration
- Measuring scale
- Abbreviation of the gas used
- Label of the device



### IN CASE OF ALARM:

- The display of concentration flashes
- alternation with « AL1 » or « AL2 » depending on the level



### IN CASE OF DEFAULT:

- The display shows « DEF »



### IN CASE OF INHIBITION:

- The display shows « INH »



### IF AMBIGUITY IS ACKNOWLEDGED (DG-TX7-X):

- Display indicates « 100 » and the status is «OVER»

The modes of the backlight are:

Green	Normal use, no alarm
Red	Superior to the alarm level 1 and/or ambiguity Acknowledgement
Yellow	Fault mode
Violet	Inhibition mode ; maintenance (temporized) or permanent



At factory setting, the intensity of the backlight and the display self-adapt, depending on the brightness of the environment. The brightness can be adjusted at fixed levels, between 0 (off) and 5 (maximum)

The



electric consumption of the device depends on the background light level (see technical specifications).

## 6.6. Wireless communication tool TLU600

All settings and tests of detectors can be done by the wireless communication tool TLU600. This communication tool and its software are compatible with all Simtronics detectors: MultiFlame, MultiTox and MultiXplo. Communication is made via infrared link (IrDA), similar but more efficient than infrared links for computers. IrDA head should not be placed facing the sun as it significantly reduces the communication with the TLU600.

Please refer to the wireless communication tool operating manual for more details.



**When a device is in communication mode with the TLU, its background light flashes. It enables the user to ensure he communicates with the requested device.**

The TLU600 menu is composed of 2 access levels allowing both settings and obtaining information about detector's status.

- level 1 : exploitation
- level 2 : Maintenance

### 6.6.1. Main screen

The main screen is composed into several data fields.

C 1		C 2		C 3	C	
C 4					1	
C 5					0	
C 6		C 7		C 8		C 9

- C1: Detector name field
- C2: Field blank if normal operation; INH- if inhibited
- C3: Field blank if normal operation; FLT- if at least one fault has occurred
- C4: State of detection: no detection, cartridge fault
- C5: State of alarm: alarm, no alarm
- C6, C7, C8 and C9: Name of keys F1, F2, F3 and F4
- C10: Wireless communication tool pictograms

Main screen displays identity and state of the detector.

```

DG-TX7
  0% LIE C4H10
[0 ----- 100%]
INFO|ADJT|MAIN|FCNX
    
```

### 6.6.2. General operation

The user can navigate through the menu with the F1 to F4 keys, whose functions change depending on the fields displayed above each key. Standard functions:

- >>>> Scroll function / next screen.
- ESC Exit the current menu and return to the previous one.
- CHG Changing displayed value.
  - VAL Validation and Check-in of the changed value.



**The changed value must be confirmed by pressing [VAL] key, otherwise the old value will be kept when leaving the menu.**

### 6.6.3. Menu structure

- **Exploitation :**  
This level enables access to the information and the status of the detectors. It does not allow the configuration operations or write access.
- **Maintenance :**  
The access to the parameters and other maintenance operations is protected by a password.

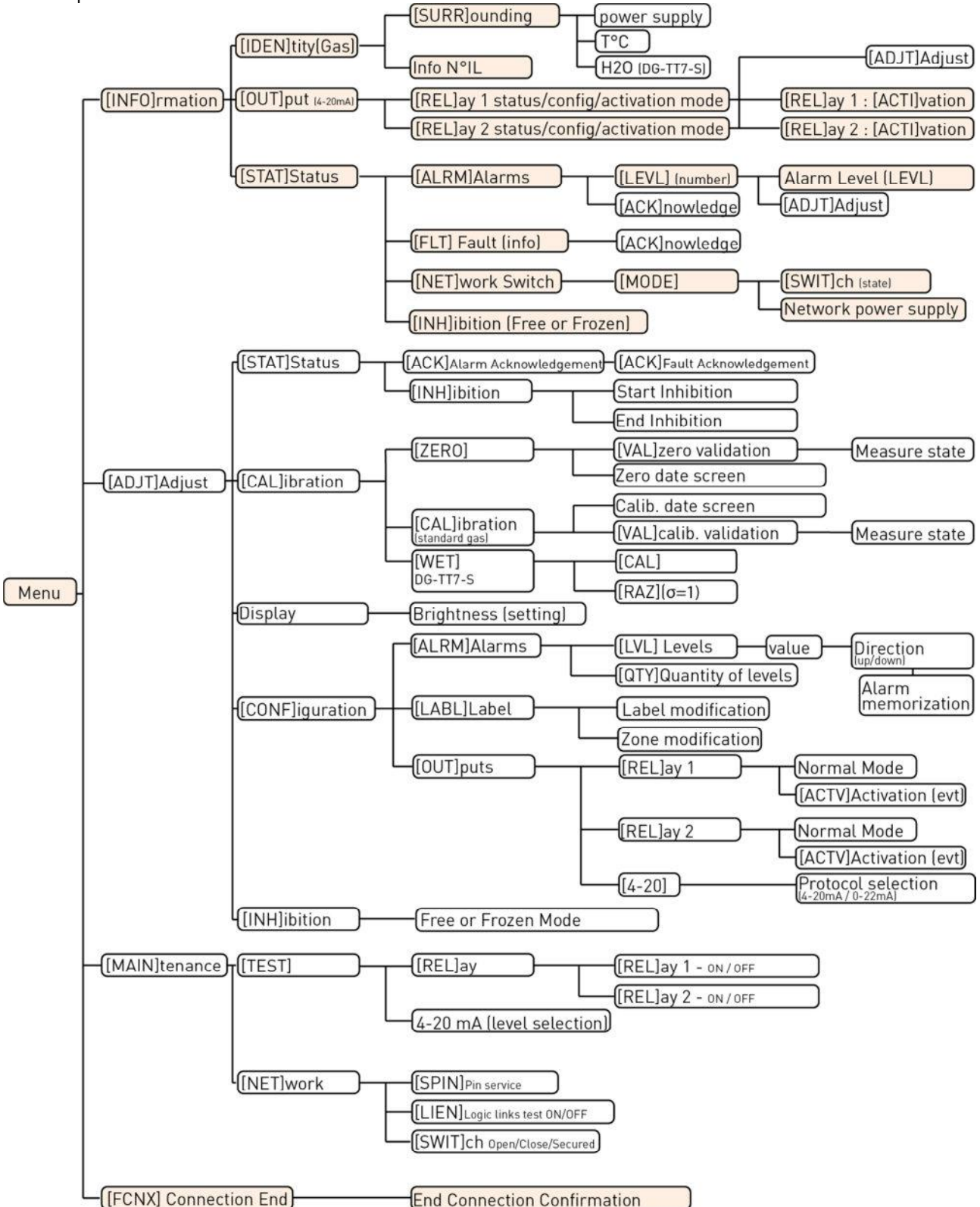

Default password (6 digits which can be changed): 012345.



## 6.7. Information menu [INFO]

The information menu contains all information concerning the identity and settings of the detector. The first screen gives the detector's reference and its serial number.

### 6.7.1. [IDEN]tity submenu

Presentation of:

- The serial number
- The device reference
- The scale and the targeted gas

Sub-menus present the board software version, the power supply voltage and the temperature read in the cartridge.

### 6.7.2. [OUT]put submenu

Presentation of:

- Analogue output current protocol (0-20 mA or 4-20 mA).
- Normal state of the relays (normally open or normally closed).
- Condition of relays activation.

Relays can be set with a level 2 access.

### 6.7.3. [STAT]e Information submenu

Presentation of:

- Number and value of activated levels.
- List of eventual faults (press F1 key to scroll through the list)
- Possibility to acknowledge alarms
- Possibility to acknowledge ambiguity (DG-TX7)

#### 6.7.3.1. [ALRM] Alarm screen

Allows setting of levels and alarms acknowledgement.

#### 6.7.3.2. [FLT.] Fault screen

Displays a list of eventual faults (press F1 key to scroll through the list) and allows their acknowledgment.

#### 6.7.3.3. Network Screen Switch

This menu and its sub-menus are used for the network detector settings. For any further details, please refer to the Syntel system operating manuals.

#### MODE SCREEN

The first line shows the operating mode of the sensor in the network (logic link test/out of order/emulation).

The second line shows if the network part of the detector is "operating" or "out of order". For any further details, please refer to the Syntel system operating manuals.

#### NETWORK SCREEN: ALIM

Information displayed:

- Voltage A: ON / OFF
- Voltage B: ON / OFF

For any further details, please refer to the Syntel system operating manuals

#### 6.7.3.4. [INH] screen

This screen is dedicated to verify the inhibition mode configuration (frozen or free). If the access level permits it, it is possible to change this setting.

### 6.8. Adjustment menu [ADJT]

This menu presents all the detector settings. All the functionalities, except alarm level acknowledgment, request access level 2.

#### 6.8.1. [STAT]us sub-menu

##### 6.8.1.1. Alarm Acknowledgement

This menu enables the acknowledgement of the memorized alarms. The alarm can be acknowledged only if the alarm condition has disappeared.

##### 6.8.1.2. Inhibition / End of inhibition

The inhibition (called permanent inhibition) is activated or deactivated manually using the menu. This function is used for deactivating the detector outputs (example: during maintenance).

The « inhibition » menu is available if the sensor is not in inhibition, maintenance inhibition or simulation.

Selecting the inhibition mode will switch the detector in inhibition mode.

The message “End of inhibition” is displayed on the TLU.

Press on “End of inhibition” to get the detector back to normal operating mode.

## 6.8.2. CALIBRATION sub-menu

### 6.8.2.1. Zero point setting

The operator can set the zero point with the wireless communication tool TLU600/610.

The detector is in maintenance inhibition mode for 10 minutes after it goes back to main screen. Use the setting menu and validate the INH command for acknowledgement.

Press F4 key to stop communication between TLU600/610 and the detector.

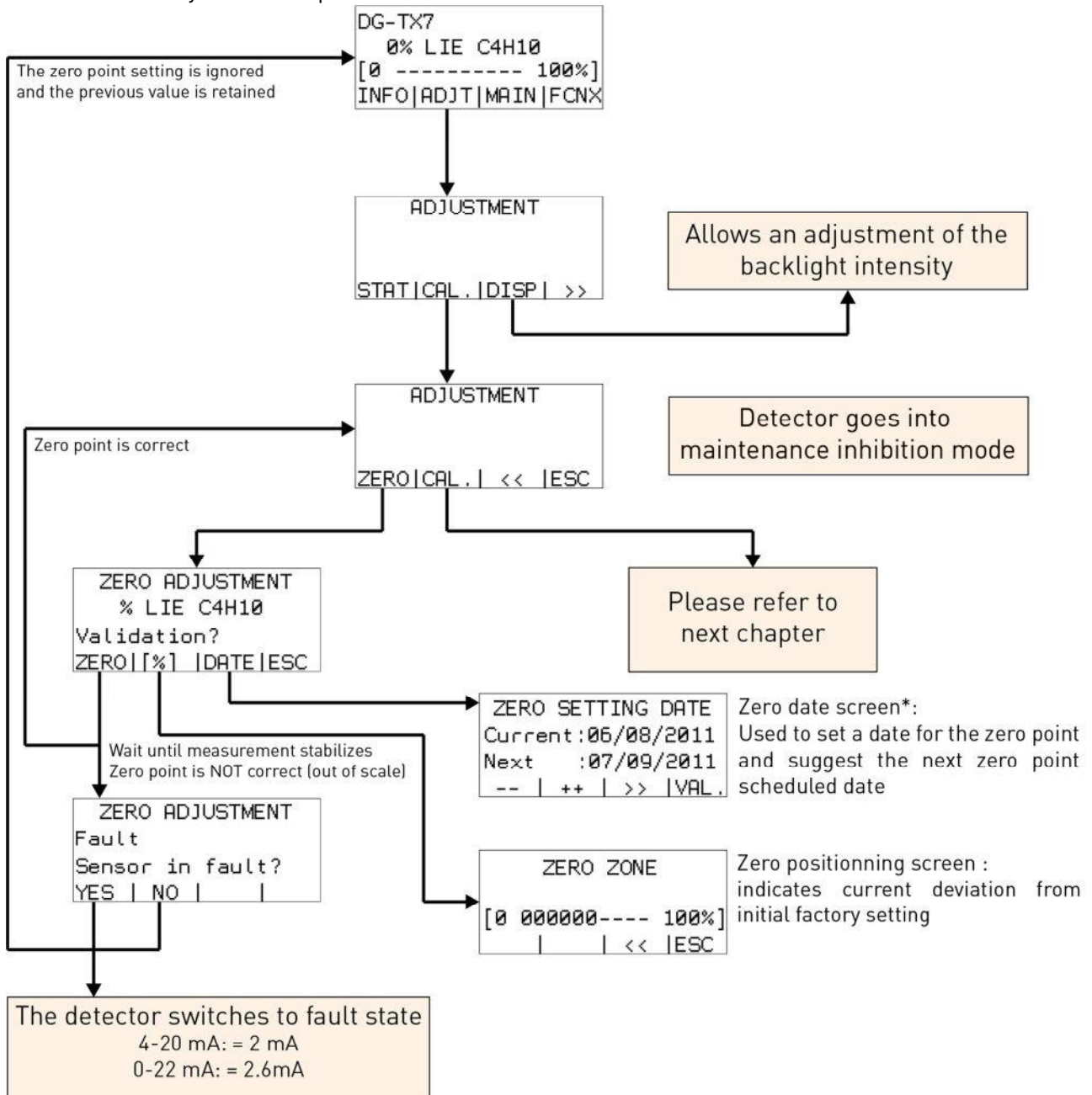

\* The device doesn't embed battery, it is then not able to keep real time. The date indication for zero or calibration points, as well as the next expected date for similar operations, are entered manually by the operator. Those data are for information only and their update is optional. mise à jour est facultative.

### 6.8.2.2. Calibration

Calibration must be made with the gas the detector is set to detect, with the SET menu (F2 key) of the wireless communication tool TLU600/610 and a calibration kit. The calibration gas should be injected at a flow rate between 30 l/h and 60 l/h.

The detector is in maintenance inhibition mode for 10 minutes after it goes back to main screen. Use the setting menu and validate the INH command for acknowledgement.

To end of communication between the TLU600/610 and the detector is done by pressing F4 key on main menu.

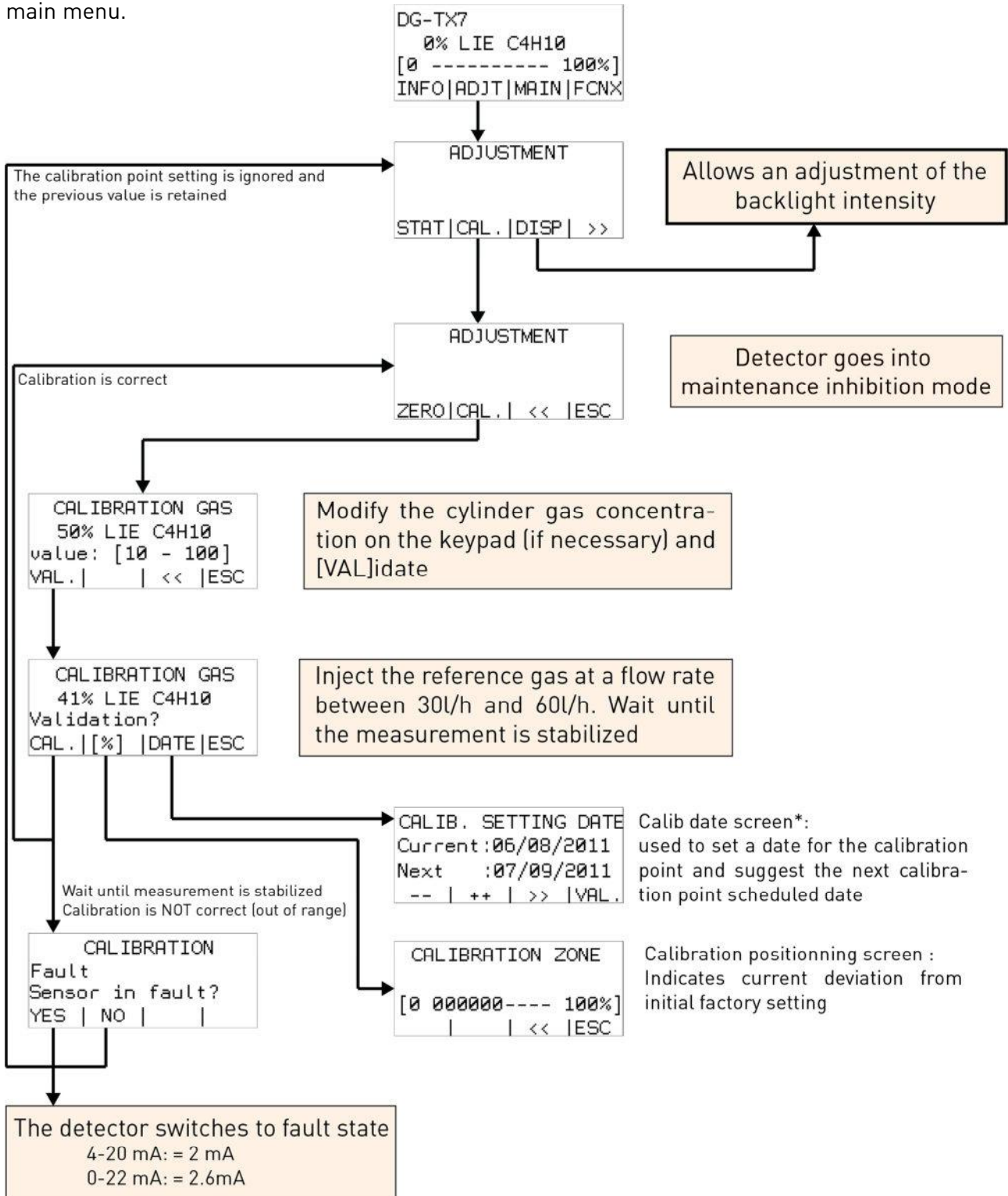

\* The device doesn't embed battery, it is then not able to keep real time. The date indication for zero or calibration points, as well as the next expected date for similar operations, are entered manually by the operator. Those data are for information only and their update is optional. mise à jour est facultative.

### 6.8.3. DISPLAY sub-menu

This menu gives access to the light intensity setting of the backlight and display:

- AUTO : Automatic adjustment depending on the lighting environment
- Level 0 : Backlight is switched off, minimum display
- Levels 1 to 4 : Intermediary levels
- Level 5 : Maximum backlight intensity

### 6.8.4. [CONF]figuration

#### 6.8.4.1. Alarm sub-menu

The menu gives access to:

- The number of alarms levels used (0 to 4).
- The trigger's value of the alarm (levels values)
- Trigger sense of alarms (up or down)
- Memorization of alarms(yes/no)

On one hand, the alarm memorization maintains relays and alarm information on the wireless communication tool. On the other hand, the current output and the concentration displayed on the wireless communication tool are always updated with the real concentration

#### 6.8.4.2. Label and zone sub-menu

This menu allows label and zone's modification. After selecting a label or a zone, the modification function operates in the same manner.

The numeric keys correspond to different alphanumeric characters. For each displayed page, the numeric keys have a different assignment.

Both "Label" and "Zone" fields are free text type for identification of the detector (name and position of the detector).

To edit fields select [label] or [zone].

- Press on the corresponding numeric key to select a figure.
- Press [➤] to go to the next figure in the field.
- Press [PAGE] to go next page.

The label or zone modification must be confirmed by pressing the key VALID, otherwise the modification is not taken into account

#### 6.8.4.3. Output configuration sub-menu

[Adjust] / [Config] / [Outputs]

This menu gives access to the configuration of the relay operating mode and to conditions of activations.

State of the relays:

Each relay can be configured:

- Normally open (not energized)
- Normally closed (energized)

Activation of the relays:

Each relay can be activated on one or several following conditions:

- Alarm
- Fault
- Inhibition

Factory setting:

- Relay 1: normally open (not energized) activated on alarm levels
- Relay 2: normally closed (energized) activated by any fault or inhibition

This menu allows you to switch the format of the output current between 4-20 mA and 0-22 mA.

### 6.8.5. [INH]ibition submenu

Maintenance inhibition can be configured in « frozen » mode (factory setting) or « free » mode.

- In « frozen » mode, the outputs (current and relay) remain in their previous state. For example, if the device displays a fault (2.0 mA), it will remain in this mode during the inhibition.
- If the device is configured in « free » mode, the current output will remain at the same level than the permanent inhibition

## 6.9. Maintenance menu [MAIN]

The maintenance menu allows the user to check if the detector is in normal operation conditions

- [Test of the relay and current outputs].

### 6.9.1. [TEST] sub-menu

#### 6.9.1.1. Relay menu

This menu gives access to activation or deactivation of the relays.

The detector goes to inhibition mode. The detector will stay in inhibition mode if the user goes back through the steps to the main menu. Otherwise, the detector will return to its “current” state.

#### 6.9.1.2. The 4-20 mA screen

This menu allows the output current to be set at a chosen value. The possible output values are: 2mA, 4mA, 8mA, 12mA, 16mA, 20mA or 22mA.

During this phase, the detector goes automatically to inhibition mode. The detector will stay in inhibition mode if the user goes back through the steps to the main menu. Otherwise, the detector will return to its “current” state.

### 6.9.2. NETWORK sub-menu

This menu gives direct access to different tests for the network. For any further details, please refer to the additional network operating manual:

- SPIN sends the detectors network identification.
- LIEN switches from normal mode to logic link mode.
- SWITCH enables the switches to go on mode open/closed/open secured.

## 6.10. Ambiguity function in combustible gas detector smart sensors

In compliance with applicable standards, the ambiguity function is activated when a detected gas concentration rises above 120% LEL. The signal is locked at 21.7 mA to protect against any false measurement due to oxygen deficiency.

This function also cuts the power of the cartridge to avoid damaging the sensitive element.



The measurement signal can only be unlocked by the operator using the TLU600/610 remote control unit. Before that, the non-presence of inflammable gas or vapour in atmosphere must be control by the user.

Even switching the power off and back on again from the control room will not unlock the signal.

The TLU displays the following screen:

```
DG-TX7      DOUT FLT.
> 100% LIE C4H10
[0 0000000000 100%]
INFO|ADJT|MAIN|FCNX
```



To clear the ambiguity, follow the instruction below with the TLU600:

INFO / STAT / ALRM / ACK. (YES)

```
ALARM ACKNOWLEDGE
+ Overshoot ack.
Confirm?
YES | >> | <<< | ESC
```



The device then goes in warming-up mode (refer to §6.3) for 90s. The detector is in inhibition mode. The current output and the default relay (if factory setting) are consequently activated.

A warming-up timer starts to countdown from 90 sec.

```
DG-TX7      INH.
Warming-Up : 87s
[0 00000----- 100%]
INFO|ADJT|MAIN|FCNX
```



Then, the inhibition is released.



## 7. HART COMMUNICATION

The HART communication authorizes an addressing of devices, allowing the communication in read/write mode.

It consists in getting connection on the current loop on which the numerical data are superimposed.

Most of the HART terminal can read these information and send commands

The use of a DD (Device Descriptor) facilitates the interface Man-Device. It can be uploaded on our website.

**HART**<sup>®</sup>  
COMMUNICATION PROTOCOL

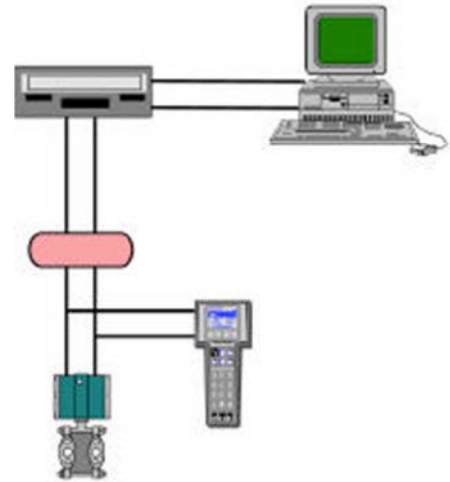

The HART output is an option. It is available only on the devices equipped with an electronic type C, in HART configuration (H):

DG-\*\*7-\*\*\*\*-\*\*H-\*\*-\*\*\*-\*C-\*



SIMTRONICS devices under HART protocol enable the use of all the functions available with the TLU600 via the HART terminal

You will find the description of the commands in a separate document (NOSP016092)

## 8. MAINTENANCE



The interventions described in this chapter must be performed by competent and qualified staff. Device performances may be affected if the present instructions are not respected.

**Cartridge unplug or device opening imperatively require power to be OFF**

### 8.1. Periodic maintenance

We recommend re-calibration of the detector every six months. Correct the zero point if needed.

#### 8.1.1. Preventive maintenance

A gas test is recommended every six months. Run a calibration if necessary. A zero point calibration with clean air has to be done first.



**We recommend using gas mixture with the target gas at 50% of the measuring range. The complement of the mixture should be Air for DG-TX7-X and air or Nitrogen for DG-TT7-K.**

If the detector enters in ambiguity mode, a test of the zero point and a gas test are recommended. We recommend cleaning the communication head window at the same time.

#### 8.1.2. Corrective maintenance

If the detection unit or the PLC signals a detector's fault, the detector must be tested directly with the wireless communication tool to determine the type of fault.

If the detector is configured in 0-22 mA output, it is possible to have a pre-diagnostic of the fault.

## 8.2. List of main faults

In addition of the current loop faults, other information are available from the wireless communication tool TLU600/610 (refer to § 6.6). If the detector does not work properly, the following table can help you to determine the causes and effects of different possible troubles.

FAULTS	CAUSES	SOLUTIONS
Backlight display switched off	Power supply failure	Check the power supply (18 and 28 V <sub>DC</sub> ) at the detection unit or the PLC output
	Continuity issue	Check line continuity
No 4-20 mA / 0-22 mA signal 3-wire cabling	Power supply failure	Check the power supply (18 and 28 V <sub>DC</sub> ) at the detection unit or the PLC output
	Continuity issue	Check line continuity
	No shunt between V+ and L+	Place the shunt
No 4-20 mA / 0-22 mA signal 4-wire cabling	Power supply fault	Check the loop with an ammeter.
ZERO_FAULT (Zero point fault)	Zero point resetting impossible	Fault memorized, even on a power supply shut down. To acknowledge this fault, make a full calibration (in general, the sensor needs to be replaced).
DRIFT_FAULT (Zero point drift)	Sensor drift: the measure is below -10%	Non-memorized fault. Automatic acknowledgement when the measure goes back above -10%. Resetting the zero point is necessary.
CALIB_FAULT (Calibration fault)	Calibration resetting impossible	Memorized fault, even on a power supply shut down. To acknowledge this fault, make a full calibration (in general, the sensor needs to be replaced).
SELFTTEST_FAULT SENSOR_FAULT (Fault material)	Material trouble (electronic part failure) on the sensor or on the electronic board of the detector	Non-memorized fault. Automatic acknowledgement when the detector is back to normal operation conditions.
	This fault is triggered if there is no sensor in the detector.	An electronic failure of the detector hardly happens. Replacing the cartridge will solve the problem most of the time.
TEMPERATURE_FAULT Temperature fault)	Temperature sensor is out of order or disconnected. The temperature sensor is in the cartridge.	Non-memorized fault. Automatic acknowledgement when the detector is back to normal operation conditions. Replace the cartridge.
No wireless communication tool connection	Detector unpowered	Check that the green LED flashes.
	Dialogue problem	Check the wireless communication tool by using it on another detector.
Detector fault (Material fault)	Electronic fault	Replace the detector

### 8.3. Replacing the cartridge

Follow the instruction in § 4.4.

### 8.4. Replacing the complete detector

If the operator needs to replace the complete detector, the easiest way is to take off the main housing from the base of the detector (for more details, refer to § 4.2.1).

As the base of the detector remains in place, cable glands do not need to be dismantled. If the detector is not replaced immediately, the “open” base must be protected against humidity, dust and shocks



**No intervention should be carried out when the detector is powered.**

## 9. WARNINGS

This document is not contractual. The product characteristics may be modified without prior notice for improvement purposes or for upgrading to meet applicable standards.

### 9.1. Safety

These devices are certified to be used in hazardous areas. Install and use the detectors in accordance with local and national regulations.

The detector must be properly grounded for protection against electric shock and minimize electrical interference.

The detector must be installed and handled only by qualified personnel.

There is no part that can be changed or repaired by the user. Calibration is done at the factory, it must be checked periodically. Return the product to the factory for any maintenance or repair outside the scope of calibration.

### 9.2. Ownership and confidentiality

The information, design data, drawings and diagrams contained in this document remain the property of SIMTRONICS and are confidential.

The information contained in this document cannot be used, either partially or wholly, nor divulged or reproduced without the prior agreement of SIMTRONICS.

## 10. WARRANTY

MultiXplo and MultiTox detectors are warranted 1 years. Application of the equipment warranty is subject to compliance with the best practices and the operating instructions contained in this manual.

The SIMTRONICS warranty shall not apply; furthermore SIMTRONICS declines all liability, for damage to equipment or harmful accidents caused by negligence, failure to supervise the equipment or failure to use the equipment in compliance with the applicable recommendations, standards and regulations stipulated in the present manual.

The SIMTRONICS warranty shall not apply to faults resulting either, from materials supplied by the Purchaser, from design imposed by the Purchaser, from servicing or maintenance carried out on SIMTRONICS equipment by a third party not explicitly authorized, or from the use of unsuitable storage conditions.

In order to guarantee correct operation of the system, any addition of equipment to the system or any modification of the installation must be validated by SIMTRONICS.

## 11. DECLARATION OF CONFORMITY

### 11.1. Product standards

MultiXplo and MultiTox detectors have been certified according to ATEX directive 2014/34/UE, EMC Directive 2014/30/UE and requirements lay down by the following standards:

EN 60079-0 / IEC 60079-0	Electrical apparatus for potentially explosive atmospheres. General requirements
EN 60079-1 / IEC 60079-1	Electrical apparatus for potentially explosive atmospheres. Flameproof enclosure "d"
EN 60079-29-1 (only DM-TX6-X)	Performance requirements of detectors for flammable gases
EN 50270	Electromagnetic compatibility. Electrical apparatus for the detection and measurement of combustible gases, toxic gases or oxygen

### 11.2. Approvals

ATEX	LCIE 11 ATEX 3081X
IECEX	LCI 11.0060X
EN 60079-29-1 (DG-TX7-X only)	INERIS 11ATEX0033

## 11.3. Marking







### 11.3.1. ATEX / IECEx versions

The detector identification label is placed on the main housing, according to ATEX directives ATEX 2014/34/UE

- Constructor:	SIMTRONICS
- Model:	DG-TX7... DG-TT7...
- Serial Number:	S/N: xxxxxxxxx (xxxxaamm)
- Type of certification:	CE0081  II 2 G / Ex d IIC T6 Gb -40°C < Ta < + 65°C
- Certificate number:	ATEX: LCIE 11 ATEX 3081X IECEx: LCI 11.0060X
- External probe SX202	LCIE 03 ATEX 6258 / -20°C < Ta < 60°C
- Standard product reference	EN 60079-29-1 : INERIS 11ATEX0033 (DG-TX7-X) (External probe version excluded)
- Warnings:	Warning - Do not open under power.
- Ingress rate:	IP66
- Power supply voltage:	VDC: 24V
- Consumption:	W: 5 W

## 12. ACCESSORIES AND SPARE PARTS

### 12.1. Accessories

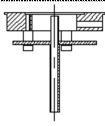
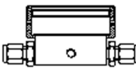
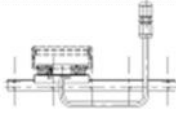
Accessories	Designation	Description	Part Number
	IRDA Remote control unit TLU 600	Required for adjustments and maintenance	TLU 600/610
	Remote control unit HART	Available for adjustments and maintenance	TLH 700
	Adapting Plate (BT05-BT606-BT10)	Used to adapt old detector (BT05-BT606) attachments to fit new generation detectors (BT10 : DG, DGi)	AS049
	Calibration cup	Fits all cartridges	AS005 ①
	Tag plate	For on-site identification of detectors	AS215
	Calibration kit	<p>The kit comprises:</p> <ul style="list-style-type: none"> <li>• One air cylinder and one pressurized cylinder containing a mixture of air and a gas of titrated concentration,</li> <li>• A 30 l/H flow rate pressure reducing and regulating valve,</li> <li>• A 3 meter pipe.</li> </ul> <p>The calibrating cup is not included calibration kit except for H<sub>2</sub> DM-TX6-X</p>	CAL-K##-....
	Filter support	For use in certain situations with molecular filters in order to block out interfering gases.	AS015 ②
	Remote calibration connection	Accessory enabling a gas supply tube to be attached near the cartridge.	AS016 ①
	Stainless steel sample flow with 2 ways	For use with gas circuit systems.	AS011-2X ①
	Duct mounting	A series of accessories for installing detectors on different types of ducts	AS02x ①



	Water, sand and dust protection	Adaptation to all cartridges, the assembly is directly in front of cartridge thanks to the nut of maintain (black on version -A).	AS019 ❸
	Suspension cable enclosure/body	Enables to connect the enclosure with the body during the maintenance operations	AS052
	Tube mounting adapter	Enables DM-T#6, DMi-TT6, DG-T#7, DGi-TT7 et GD10P lines to be mounted on a 2 inch to 2.5 inch diameter tube	AS053
	Display protection	Enables to protect the infrared communication zone in order to better the dialog with the TLU in full sun	AS047
	Multi-position socket (wall or tube mounting)	Enables to fix the device from the top. Can be orientated in all directions.	AS048
	Weather protection (wall or tube mounting)	Dedicated to protect apparatus from sun / rain / snow.	AS056-250
	IRDA cap	Replaces the display and its backlight by a fixed IRDA communication head	Factory setting type 00D : DG-**7-****-***-**-00D-*+*
	SX202 calibration cup	screwed on the sensor	AS205

- ❶ Detector sensitivity is not modified, response time depend on the flow rate used for injection. A flow rate between 0.5 L/min and 1 L/min should comply with "standard" response time.
- ❷ Detector sensitivity is not modified; response time can increase depending on the molecular filter used.
- ❸ Detector sensitivity is not modified, response time (T90) (natural diffusion condition) is increased by 50%.

## 12.2. Spare parts

- O-ring spare parts
- For the base (All models) - O-ring kit BT10
- Lubricant for explosion proof seal and thread: MOLYKOTE Brand, reference P40.
- Combustible gas detector cartridges : DM-SX6-SADG-XX0-X0 (gas to specify)
- Catharometer cartridges : DM-SX6-SADG-KX0-X0 (gas and range to specify)

### 12.3. Gas table codes & range table codes

Regarding reference F2 = DG (100% LEL), the following table defines what SIMTRONICS uses of correspondence between %vol and 100% LEL.

F1	Nom produit	Name of compound	Formule Formula	% vol équivalent à 100 % LIE / LEL
63	1,3-butadiène	1,3-Butadiene	C <sub>4</sub> H <sub>6</sub>	1.4
64	1-Butène	1-Butene	C <sub>4</sub> H <sub>8</sub>	1.6
8	Acétone	Acetone	C <sub>3</sub> H <sub>6</sub> O	2.6
2	Acétylène	Acetylene	C <sub>2</sub> H <sub>2</sub>	2.2
39	Ammoniac	Ammonia	NH <sub>3</sub>	16.0
13	Benzène	Benzene	C <sub>6</sub> H <sub>6</sub>	1.2
28	Chlorure de vinyle	Vinyl chloride	C <sub>2</sub> H <sub>3</sub> Cl	3.6
73	Cyclohexane	Cyclohexane	C <sub>6</sub> H <sub>12</sub>	1.3
6	Diméthyle éther	Dimethyl ether	C <sub>2</sub> H <sub>6</sub> O	2.7
56	Ethane	Ethane	C <sub>2</sub> H <sub>6</sub>	3.0
5	Ethanol	Ethanol	C <sub>2</sub> H <sub>5</sub> OH	3.3
3	Ethylène	Ethylene	C <sub>2</sub> H <sub>4</sub>	2.7
76	Heptane	Heptane	C <sub>7</sub> H <sub>16</sub>	1.1
30	Hydrogène	Hydrogen	H <sub>2</sub>	4.0
10	Isobutane	Iso-butane	i-C <sub>4</sub> H <sub>10</sub>	1.8
60	Isopropanol	2-Propanol	C <sub>3</sub> H <sub>8</sub> O	2.0
17	Méthane	Methane	CH <sub>4</sub>	5.0
19	Méthanol	Methanol	CH <sub>3</sub> OH	5.5
38	n-Butane	n-Butane	C <sub>4</sub> H <sub>10</sub>	1.9
12	N-Hexane	N-Hexane	C <sub>6</sub> H <sub>14</sub>	1.1
11	Pentane	Pentane	C <sub>5</sub> H <sub>12</sub>	1.4
9	Propane	Propane	C <sub>3</sub> H <sub>8</sub>	2.2
7	Propylène / propène	Propylene / propene	C <sub>3</sub> H <sub>6</sub>	2.0
15	Styrène	Styrene	C <sub>8</sub> H <sub>8</sub>	1.1
14	Toluène	Toluene	C <sub>7</sub> H <sub>8</sub>	1.2
77	Xylène	Xylene	C <sub>6</sub> H <sub>4</sub> (CH <sub>3</sub> ) <sub>2</sub>	1.0

According to the new references: DG-TX7-F1F2-X□□-□□-□□□-□-□-□

F1	Formula	Gas name	Comment	F2	Range
01	AsH <sub>3</sub>	Arsine		00	Pas
02	C <sub>2</sub> H <sub>2</sub>	Acetylene		AA	1 ppm
03	C <sub>2</sub> H <sub>4</sub>	Ethylene		AB	2 ppm
04	C <sub>2</sub> H <sub>4</sub> O	Ethylene oxide		AC	5 ppm
05	C <sub>2</sub> H <sub>6</sub> O	Ethanol		AD	10 ppm
06	C <sub>2</sub> H <sub>6</sub> O	Dimethylene		AE	20 ppm
07	C <sub>3</sub> H <sub>6</sub>	Propene		AF	50 ppm
08	C <sub>3</sub> H <sub>6</sub> O	Acetone		AG	100 ppm
09	C <sub>3</sub> H <sub>8</sub>	Propane		AH	200 ppm
10	i-C <sub>4</sub> H <sub>10</sub>	i-Butane		AJ	500 ppm
11	C <sub>5</sub> H <sub>12</sub>	Pentane		AK	1000 ppm
12	C <sub>6</sub> H <sub>14</sub>	Hexane		AL	2000 ppm
13	C <sub>6</sub> H <sub>6</sub>	Benzene		AM	5000 ppm
14	C <sub>7</sub> H <sub>8</sub>	Toluene		AN	10000 ppm
15	C <sub>8</sub> H <sub>8</sub>	Styrene		AP	3000 ppm
16	CH <sub>2</sub> Cl <sub>2</sub>	Dichloromethane		AQ	25 ppm
17	CH <sub>4</sub>	Methane		BA	1 %Vol
18	CH <sub>4</sub>	Methane	(Biogas)	BB	2 %Vol
19	CH <sub>4</sub> O	Methanol		BC	5 %Vol
20	Cl <sub>2</sub>	Chlorine		BD	10 %Vol
21	CO	Carbon monoxide	(H <sub>2</sub> S comp)	BE	20 %Vol
22	CO	Carbon monoxide		BF	50 %Vol
23	CO <sub>2</sub>	Carbon dioxide		BG	100 %Vol
24	CO <sub>2</sub>	Carbon dioxide	(CH <sub>4</sub> immune)	BH	3 %Vol
25	COCl <sub>2</sub>	Phosgene		BJ	25 %Vol
26	X	All gases		BK	4 %Vol
27	CTFE	CTFE		BL	21 %Vol
28	CVM	Vinylchloride		BM	24 %Vol
29	F <sub>2</sub>	Fluorine		BN	17 %Vol
30	H <sub>2</sub>	Hydrogen		BZ	Other % vol
31	H <sub>2</sub> S	Hydrogen sulphide		DE	20 %LIE (1)
32	HCl	Hydrogen chloride		DF	50 %LIE (1)
33	HCN	Hydrogen cyanide		DG	100 %LIE (1)
34	He	Helium		DH	30 %LIE (1)
35	HF	Hydrogen fluoride		DJ	15 %LIE (1)
36	MCPE	MCPE		DP	125 %LIE (1)
37	N <sub>2</sub>	Nitrogen		EE	20 %LIE (2)
38	n-C <sub>4</sub> H <sub>10</sub>	n-Butane		EF	50 %LIE (2)
39	NH <sub>3</sub>	Ammonia		EG	100 %LIE (2)
40	NO	Nitric oxide		GC	5 LELm
41	NO <sub>2</sub>	Nitrogen dioxide		KA	1 ppm*m
42	O <sub>2</sub>	Oxygen		JB	2 ppm*m
43	O <sub>3</sub>	Ozone		KC	5 ppm*m
44	PFBA	PFBA		KD	10 ppm*m
45	R22	Chlorodifluoromethane		KE	20 ppm*m
46	R23	Trifluoromethane		KF	50 ppm*m
47	SO <sub>2</sub>	Sulphur dioxide		KG	100 ppm*m
48	C <sub>5</sub> H <sub>10</sub>	Cyclopentane		KH	200 ppm*m
49	VC <sub>2</sub>	VC2		KJ	500 ppm*m
50	D40	White Spirit		KK	1000 ppm*m
51	/	Gasoil		KL	2000 ppm*m

F1	Formula	Gas name	Comment	F2	Range
52	/	Super 95		KM	5000 ppm*m
53	/	Super 98		KN	10000 ppm*m
54	/	LPG		ZZ	Other
55	C <sub>2</sub> H <sub>5</sub> Cl	Ethyl chloride			
56	C <sub>2</sub> H <sub>6</sub>	Ethane			
57	C <sub>3</sub> H <sub>3</sub> N	Acrylonitrile/Vinyl cyanide			
58	C <sub>3</sub> H <sub>6</sub> Cl <sub>2</sub>	Dichloroethane			
59	C <sub>3</sub> H <sub>6</sub> O	Propylene oxide			
60	C <sub>3</sub> H <sub>8</sub> O	Isopropyl alcohol			
61	C <sub>3</sub> H <sub>8</sub> O	Propyl alcohol			
62	C <sub>4</sub> H <sub>10</sub> O	Butanol			
63	C <sub>4</sub> H <sub>6</sub>	Butadiene			
64	C <sub>4</sub> H <sub>8</sub>	Butene			
65	C <sub>4</sub> H <sub>8</sub> O	Butanal			
66	C <sub>4</sub> H <sub>8</sub> O	Methyl-ethyl-ketone(MEK)			
67	C <sub>4</sub> H <sub>9</sub> O <sub>2</sub>	Ethyl acetate			
68	C <sub>5</sub> H <sub>10</sub> O	Methyl-isopropyl-ketone			
69	C <sub>5</sub> H <sub>10</sub> O <sub>2</sub>	Propyl acetate			
70	C <sub>5</sub> H <sub>12</sub> O	Isopentanol			
71	C <sub>5</sub> H <sub>8</sub>	Isoprene			
72	C <sub>6</sub> H <sub>10</sub>	D-limonene			
73	C <sub>6</sub> H <sub>12</sub>	Cyclohexane			
74	C <sub>6</sub> H <sub>12</sub>	Hexene-1			
75	C <sub>6</sub> H <sub>12</sub> O <sub>2</sub>	Butyl acetate			
76	C <sub>7</sub> H <sub>16</sub>	Heptane			
77	C <sub>6</sub> H <sub>4</sub> (CH <sub>3</sub> ) <sub>2</sub>	Xylene			
78	C <sub>7</sub> H <sub>12</sub> O <sub>2</sub>	N-butyacrylate			
79	C <sub>2</sub> H <sub>4</sub>	Ethylene	(special)		
80	C <sub>3</sub> H <sub>8</sub>	Propane	(special : low CH <sub>4</sub> )		
81	CH <sub>4</sub>	Methane			
82	C <sub>8</sub> H <sub>18</sub>	Octane			
83	CF <sub>3</sub> -CFH <sub>2</sub>	R134a			
84	/	Kerosene			
85	C <sub>2</sub> Cl <sub>4</sub>	Tetrachloroethene			
86	C <sub>2</sub> H <sub>4</sub>	Ethylene			
87	HC lourd	F1850	Special customer		
88	(CH <sub>3</sub> ) <sub>3</sub> COCH <sub>3</sub>	MTBE			
SA	Xs	Special combustible gas	App SA		
CS	H <sub>2</sub>	Hydrogen in Argon	Complement Argon		
CU	H <sub>2</sub>	Hydrogen in Azote	Complement Azote		

## 13. CONFORMITY CERTIFICATE

	<b>DECLARATION UE DE CONFORMITÉ</b> <b>EU CONFORMITY DECLARATION</b>	Réf : +NOSP0017344 Rév. 0
---	---	------------------------------

Nous, **SIMTRONICS**  
 We, **792, Avenue de la Fleuride**  
**13400 AUBAGNE**

Déclarons, sous notre seule responsabilité, que le matériel suivant:  
 Declare, under our sole responsibility that the following equipment:

Type / Type	DETECTEUR MULTIGAZ / MULTIGAZ DETECTOR
Modèle / Models	DG
Marquage / ATEX marking	CE 0081  II 2 G / Ex d IIC T6 Gb -40°C ≤ Ta ≤ +65°C
N° attestation CE de type / EC type-examination certificate N°	LCIE 11 ATEX 3081X
Notification de l'Assurance Qualité de la production / Quality Assurance Notification Number	LCIE 03 ATEX Q 8046

Est conçu et fabriqué en conformité avec les Directives applicables et les normes harmonisées suivantes :  
 Is designed and manufactured in compliance with the following applicable Directives and standards:

ATEX	Directive 94/9/CE (jusqu'au 19 avril 2016) Directive 2014/34/UE (à partir du 20 avril 2016)	EN 60079-0:2012+A11 :2013(*) EN 60079-1 : 2014 (*)
	Directive 94/9/EC (up to 19 April 2016) Directive 2014/34/EU (from 20 April 2016)	
CEM /EMC	Directive 2004/108/CE (jusqu'au 19 avril 2016) Directive 2014/30/UE (à partir du 20 avril 2016)	EN 60079-29-1 :2007 EN 50270 : 2006
	Directive 2004/108/EC (up to 19 April 2016) Directive 2014/30/EU (from 20 April 2016)	

La Directive Basse Tension 2006/95/CE ou 2014/35/UE n'est pas applicable à ce produit  
 Low Voltage Directive 2006/95/EC or 2014/35/EU is not applicable to this equipment.

L'organisme notifié en charge du suivi de la Directive ATEX est The notified body in charge of monitoring the ATEX Directive is	LCIE 33, Avenue du Général Leclerc 92260 FONTENAY AUX ROSES France
Numéro d'identification / Identification Number :	0081

Ce matériel ne doit être utilisé qu'à ce pour quoi il a été conçu et doit être installé en conformité avec les règles applicables et suivant les recommandations du fabricant.  
 This equipment shall be used for the purpose for which it has been designed and be installed in accordance with relevant standards and with manufacturer's recommendations.

Nous, soussignés SIMTRONICS, déclarons par la présente que le produit spécifié ci-dessus est conforme aux Directives et aux Normes listées.  
 We, undersigned SIMTRONICS, declare that the product specified above conforms to the listed Directives and standards.

A Aubagne le 13 avril 2016/ Aubagne, April 13th, 2016

Salvator LA PIANA  
 Directeur d'établissement  
 Plant Manager



Eric CALVO  
 Responsable ATEX  
 ATEX Manager



Elodie VENEZIANO  
 Responsable qualité  
 Quality Manager



(\*) La conformité à la EN 60079-0 et EN 60079-1 a été obtenue sur la base de la version 2009 et 2007, cependant les modifications apportées par la version 2013 et 2014 ne la remettent pas en cause / Compliance with the EN 60079-0 and EN60079-1 has been obtained on the basis of the 2009 and 2007 version, however, the changes of the 2013 and 2014 version does not affect it.

	<b>DECLARATION UE DE CONFORMITÉ</b> <b>EU CONFORMITY DECLARATION</b>	Réf : +NOSP0017351 Rév. 0
---	---	------------------------------

Nous, **SIMTRONICS**  
We, **792, Avenue de la Fleuride**  
**13400 AUBAGNE**

Déclarons, sous notre seule responsabilité, que le matériel suivant:  
*Declare, under our sole responsibility that the following equipment:*

Type / Type	SONDE / SENSOR
Modèle / Models	SX 202
Marquage / ATEX marking	CE 0081  II 2 G/ Ex d IIC T6 Gb -20°C ≤ Ta ≤ +60°C
N° attestation CE de type / EC type-examination certificate N°	LCIE 03 ATEX 6258
Notification de l'Assurance Qualité de la production / Quality Assurance Notification Number	LCIE 03 ATEX Q 8046

Est conçu et fabriqué en conformité avec les Directives applicables et les normes harmonisées suivantes :  
*Is designed and manufactured in compliance with the following applicable Directives and standards:*

ATEX	Directive 94/9/CE (jusqu'au 19 avril 2016) Directive 2014/34/UE (à partir du 20 avril 2016)	EN 60079-0 : 2012+A11 :2013 (*) EN 60079-1 : 2014 (*)
	Directive 94/9/EC (up to 19 April 2016) Directive 2014/34/EU (from 20 April 2016)	

La Directive CEM 2014/30/UE ou 2004/108/CE n'est pas applicable à ce produit  
EMC Directive 2014/30/EU or 2004/108/EC is not applicable to this equipment.

La Directive Basse Tension 2006/95/CE ou 2014/35/UE n'est pas applicable à ce produit  
Low Voltage Directive 2006/95/EC or 2014/35/EU is not applicable to this equipment.

L'organisme notifié en charge du suivi de la Directive ATEX est <i>The notified body in charge of monitoring the ATEX Directive is</i>	LCIE 33, Avenue du Général Leclerc 92260 FONTENAY AUX ROSES France
Numéro d'identification / Identification Number :	0081

Ce matériel ne doit être utilisé qu'à ce pour quoi il a été conçu et doit être installé en conformité avec les règles applicables et suivant les recommandations du fabricant.  
*This equipment shall be used for the purpose for which it has been designed and be installed in accordance with relevant standards and with manufacturer's recommendations.*

Nous, soussignés SIMTRONICS, déclarons par la présente que le produit spécifié ci-dessus est conforme aux Directives et aux Normes listées.  
We, undersigned SIMTRONICS, declare that the product specified above conforms to the listed Directives and standards.

A Aubagne le 13 avril 2016/ *Aubagne, April 13th, 2016*

Salvator LA PIANA  
Directeur d'établissement  
Plant Manager



Eric CALVO  
Responsable ATEX  
ATEX Manager

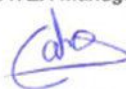

Elodie VENEZIANO  
Responsable qualité  
Quality Manager



(\*) La conformité à la EN 60079-0 et EN 60079-1 a été obtenue sur la base de la version 2009 et 2007, cependant les modifications apportées par la version 2013 et 2014 ne la remettent pas en cause / *Compliance with the EN 60079-0 and EN60079-1 has been obtained on the basis of the 2009 and 2007version, however, the changes of the 2013 and 2014 version does not affect it.*