

ARIES®-MLX

Multi-Loop Intelligent Fire Alarm-Suppression Control Unit

FEATURES

- Triple redundancy safeguards reduce the risk of inadvertent activation caused by microprocessor failure
- Out-of-the-box features:
 - 2 SLCs with up to 255 addresses each (510 total)
 - 4 x 40 Display-Keypad
 - 4 Programmable soft-switches
 - 2 NACs and 2 R-NACs
 - 3 Programmable and 1 Trouble Form-C Relays
 - 2 Auxiliary Power Outputs, 2 amps each
 - USB ports for PC and printer
 - RS-232 ports for graphics
 - 120/240V, 50/60 Hz AC input
 - 5.4 A Power Supply Unit
 - Charging Capacity of 165 AH
 - RS-485 Annunciator bus
 - 2 and 3 Tier enclosures that fit between 16 inch studs
- Control for wide array of fire suppression systems:
 - Kidde Fire Systems ECS™ Clean Agent
 - Kidde Fire Systems ADS™ Clean Agent
 - Kidde® Inert Gases
 - Kidde® HP CO2
 - Kidde® LP CO2
 - Kidde® WHDR™ Wet Chemical
 - Kidde® IND™ Dry Chemical
 - Fenwal® Initiators
 - Chemetron® Solenoids
 - Marioff® HI-FOG® Water Mist
 - Sprinkler Supervisory
 - Deluge/Pre-action
 - Foam and Foam/Water
- Expandable with flexible programming:
 - Add up to 6 SLC loops
 - 96 relays or 72 release/NAC circuits to base system
 - Networkable up to 64 nodes (130,560 addresses)
 - Networkable with ARIES® NETLink, FenwalNET™ 6000, and Chemetron® MICRO MLX control units
- High level serviceability and diagnostics:
 - Pluggable terminal blocks
 - Ground fault detection by circuit
 - 10,000 event log capacity
 - Internet connectivity with e-mail notification feature
- External connectivity includes DACT, Modbus RTU & TCP/IP, BACnet MS/TP & IP
- Backwards compatible with installed investment:
 - SmartOne® SLC devices & protocol
 - Kidde Control Heads and Actuators
 - Fenwal Initiators
 - Upgrade from legacy PEGAsys™ or FENWALNET™ 2000 panels via a simple retrofit kit
- Seamlessly integrated HSSD®, ASD and LHD
- Approvals/Listings:
 - FM Approved
 - UL Listed to ANSI/UL864, 10th edition
 - ULC
 - California State Fire Marshal
- RoHS compliant



DESCRIPTION - CONTROL UNIT

The ARIES®-MLX is an intelligent, addressable, multi-loop Fire Alarm Suppression control unit that supports Kidde Fire Systems' wide array of suppression products and is backward compatible with legacy Kidde Fire Systems, Fenwal Protection Systems and Chemetron Fire Systems agent release devices. Its versatile, expandable and networkable platform provides unique features and benefits for demanding applications that require protection of multiple hazards. Its modular architecture enables easy field expansion from the base 2-SLC unit that supports 510 addressable devices (255 per circuit) to an 8-SLC system that supports 2,040 addressable devices. 64 such individual control units or nodes support a total of 130,560 addresses (some limitations apply).

The ARIES-MLX is compact, fits between wall stud dimensions, and is designed to be quick and easy to install. Configuration and maintenance is easy with a User Interface that has 4 programmable buttons, easy-to-use configuration software and programming language, the capability to send email alerts and a 10,000 event log.

Main Controller Board - MCB

The Main Control Board (MCB) contains the system's central processing unit (CPU) and all of the primary circuits. The MCB is the heart of the system, controlling the operation and supervision of all system modules and software. It receives loop device data, processes the data based on pre-programmed instructions, and transmits output commands to the output modules, field devices, and display(s). The MCB is mounted to the enclosure using hinged standoffs which permit the board to swing left and enable easy access to the Power Management and Power Supply Units (PMU and PSU).

User Interface - UI

The user interface (UI) consists of a built-in keypad and display which allow an operator and/or installer to perform system function, enter the security password, operate soft keys, navigate the system menus, configure and test the entire ARIES-MLX system.

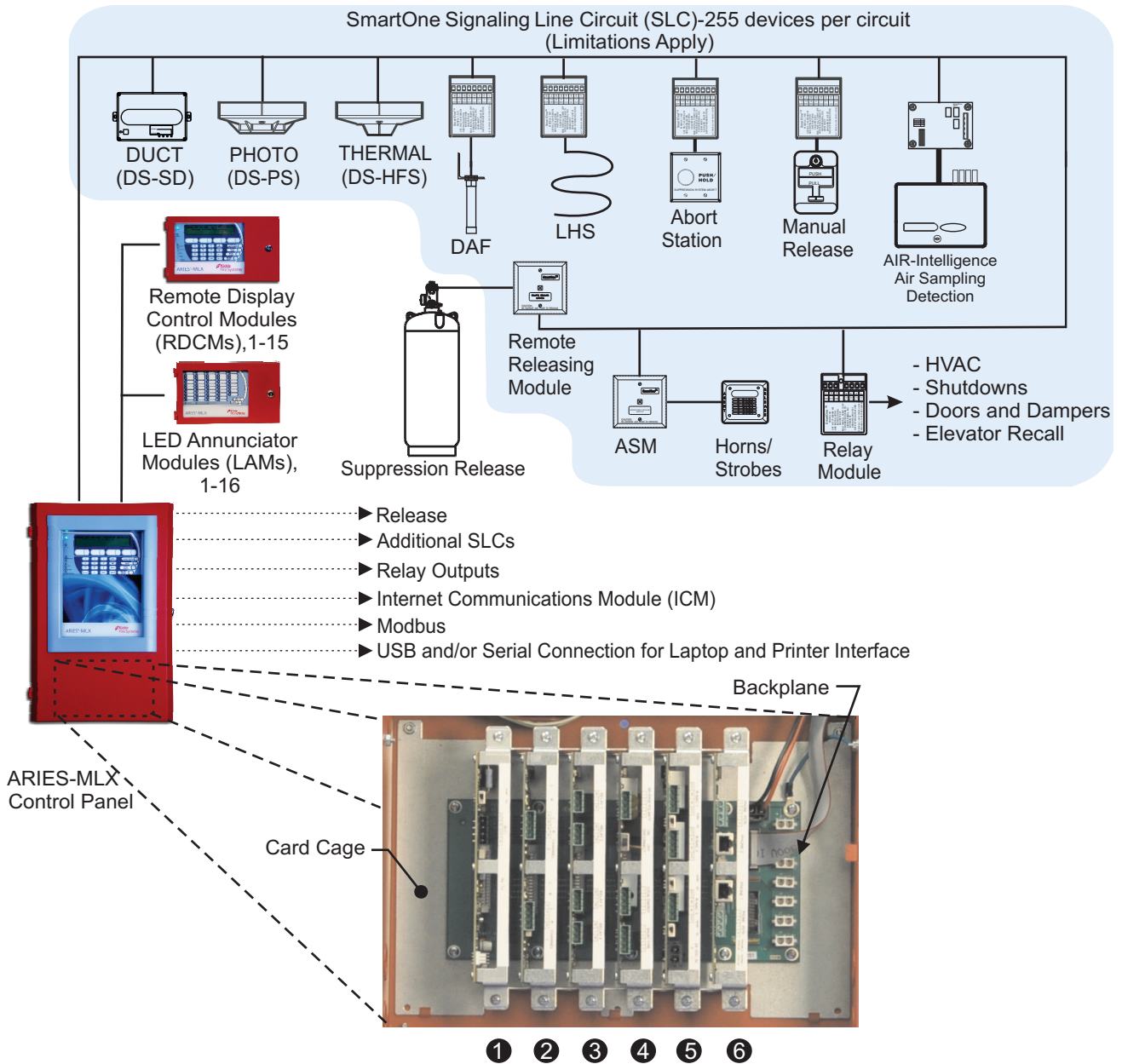

Note: 6 slots available per card cage, up to 4 cages per control unit.

Cards Supported in Card Cage:

- Signal Line Circuit (SLC) Card
- Network Interface Card (NIC)
- Relay Card
- City Tie Card
- Release/Notification Appliance Circuit (R-NAC) Card
- Digital Alarm Communicator Transmitter (DACT)
- Internet Communication Module (ICM)

Figure 1. Modular Design to Meet the Most Demanding Applications

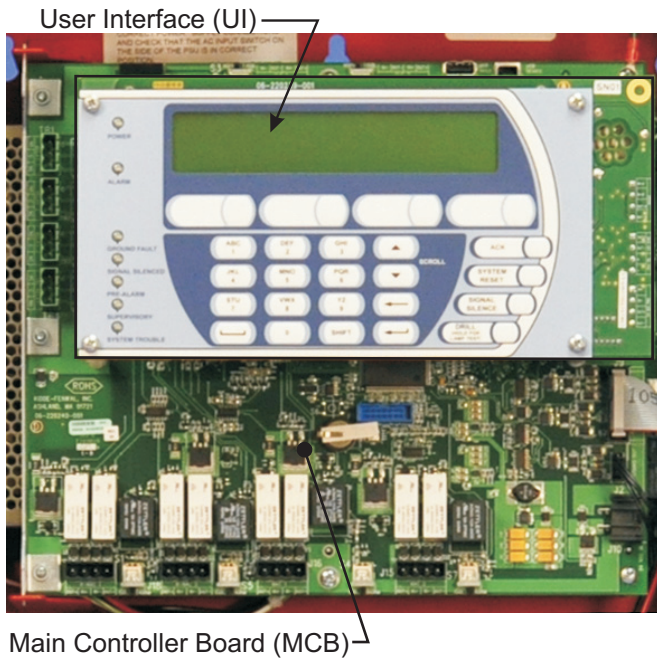

Figure 2. Main Controller Board and User Interface

MAIN CONTROLLER BOARD SPECIFICATION

MCB Signaling Line Circuits

Number of Circuits:	Two
Device Capacity:	255 devices per SLC (limitations apply)
Wiring Classes:	Class A, B or X
T-Tapping Allowed:	Class B only
Circuit Voltage:	Nominal 24 VDC
Maximum Line Resistance:	40 ohms per loop
Maximum Conductor-to-Conductor Capacitance:	0.5 μ F
Maximum SLC Loop Capacitance to Earth Ground:	0.5 μ F
Maximum Current:	350 mA (short circuit)
Wiring Specifications:	#14AWG - #18AWG, twisted, unshielded, low-capacitance, fire-alarm wire

MCB Notification Appliance Circuits

Number of Circuits:	Two
Compatible devices:	24 VDC regulated polarized horns, strobes, bells, etc.
Wiring Classes:	Class A or B
Power Limited:	Yes
Synchronized Strobes:	Yes, configurable
Maximum Output Current:	Non-Synchronized: 2.0 A Synchronized: 1.5 A
Maximum Output Circuit Terminal Voltage:	28 VDC
Minimum Output Circuit Terminal Voltage:	20 VDC
End-of-Line Resistor:	10 K, 5%, 1/2 W
Maximum Allowable Voltage Drop:	2 V at End-of-Line

MCB Release/Notification Appliance Circuits

Number of Circuits:	Two
Individually Configurable for Notification or Release:	Yes
Notification Specifications:	Same as NAC

MAIN CONTROLLER BOARD SPECIFICATION

Release Circuit Specifications:

Compatible devices:

- Kidde®, Fenwal® or Chemetron® control heads
- Water Mist Solenoid valves
- FM Release Panel Group 3 (any FM Approved Solenoid Valve rated 22W and below)
- Metron actuators
- Set of P/N 93-002009-004 Initiators
- Set of P/N 31-199932-004 Initiators
- Set of P/N 93-191001-001 Initiators

Device type configurable: Yes, with device on-time after activation

Wiring Classes:

- **Solenoids:** Class A or B
- **Actuators:** Class B
- **Initiators:** Class B

Power Limited: Yes, requires In-Line Releasing Device

Maximum Output Circuit Terminal Voltage: 28 VDC

Allowable Voltage Drop: 2 V

MAIN CONTROLLER BOARD SPECIFICATION

MCB Relays

Number and type: 3 Programmable and 1 Trouble Relay

Relay Form: Form-C (1 NO + 1 NC)

Rating: 3A @ 30 VDC/120 VAC

MCB RS-232 Serial Ports

Number of Ports: 2

Specifications: Bi-Directional 9600 Baud, 8 Data Bits, 1 Stop Bit, No Parity

MCB RS-485 Annunciator Port

Number of Ports: 1

Compatible Devices:

- **RDCM** Max. 15 devices
- **R-LAM** Max. 16 devices
- **ATM-L** Max. 16 devices
- **ATM-R** Max. 16 devices

Compatible Device Maximum: 31 in any order

Wiring Type: Twisted, shielded, low-capacitance fire alarm wire

Wiring Minimum Size: AWG 18

Maximum wire length: 4,000 ft. (1,219 m)

MCB USB Device Ports:

Number of Ports: 2

Power Supply

The ARIES-MLX control unit requires a minimum of one Power Supply Unit and one Power Management Unit (PMU) Board for operation. Additional Power Supply Units may be added, based on calculated power requirement (refer to Battery Calculations in the ARIES-MLX Installation, Operation, and Maintenance Manual, P/N 06-236530-001).

One PMU board is needed to control up to 2 Power Supply Units. The ARIES-MLX control unit design offers optional Power Supply Units and Power Management Unit (PMU) Board to expand the available power to meet additional power requirements.

Each enclosure of the ARIES-MLX control unit can provide 20 Amps of power supply capacity and the system can charge up to 165-AH batteries.

POWER SUPPLY & MANAGEMENT SPECIFICATION

Number of PMUs per control unit	Minimum: 1 Maximum: 4
Number of PSUs per PMU	Minimum: 1 Maximum: 2
Primary AC Input Power:	
• 1 PSU:	120 VAC, 50/60 Hz, 3.2 A 240 VAC, 50/60 Hz, 1.6 A
• 2 PSU:	120 VAC, 50/60 Hz, 6.4 A 240 VAC, 50/60 Hz, 3.2 A
Allowable Input Voltage	110-120 VAC Nominal, 50/60 Hz 220-240 VAC Nominal, 50/60 HZ
Secondary DC Output:	
• 1 PSU:	5.4 A @ 27.6 VDC
• 2 PSU:	10.8 A @ 27.6 VDC
Voltage Selection:	Slide switch on PSU
Trouble Relay Contact Rating:	1.0 A @ 30 VDC (resistive)
Battery Charging Circuit Voltage:	27.0 VDC (nominal)
Maximum Battery Charging Circuit Current:	
• 1 PSU:	4 A
• 2 PSU:	8.9 A
Allowable Battery Type:	2 x 12 VDC Sealed Lead-Acid Only
Maximum Battery Capacity:	165 AH
Auxiliary Outputs:	2 Class B per PMU, power-limited
Auxiliary Output Operating Voltage Range:	19.2 - 27.6 VDC
Auxiliary Output Maximum Current:	2 Amps
Auxiliary Output Maximum Load Input Capacitance:	470 μ F

Backplane & Card Cage

The Card Cage is a metal frame which supports and secures up to six Expansion/Functional Cards plugged into the Backplane. The frame is fixed to the Backplane and mounts to the enclosure in the second- or third-tier positions. A fully expanded ARIES-MLX system can accommodate a maximum number of four Card Cages or 24 card slots in total. Unlike installation intensive control units, the ARIES-MLX features virtually plug-and-play architecture in that the control unit is intelligent enough to detect the type of card plugged in.

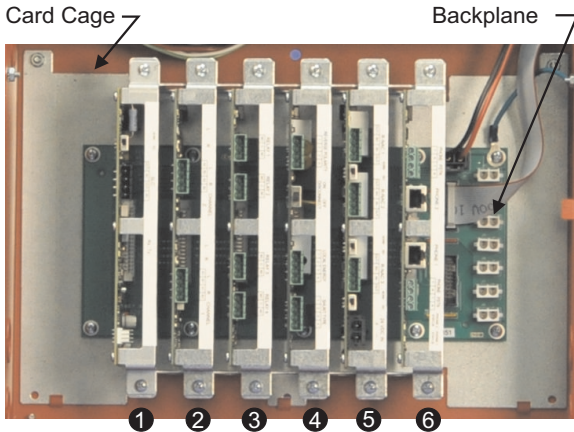

- ① Signal Line Circuit (SLC) Card
- ② Network Interface Card (NIC)
- ③ Relay Card
- ④ City Tie Card
- ⑤ Release/Notification Appliance Circuit (R-NAC) Card
- ⑥ Digital Alarm Communicator Transmitter (DACT)

Figure 3. Backplane and Card Cage

CARD CAGE SPECIFICATION

Module Capacity each:	Maximum 6
Number of Card Cages:	Maximum 4 per MCB
Number of Expansion/ Functional cards:	Maximum 24 per MCB

Signaling Line Circuits - SLC

The MCB incorporates two SLC circuits. At the rate of one SLC per expansion card, up to six additional circuits can be included in one control unit. The Expansion Card occupies a single slot in the Card Cage Assembly and plugs directly into the backplane.

All SLCs are suitable for Class A, Class B and Class X wiring. A disconnect switch provides the means to physically isolate the circuit from its associated field wiring. Communications LEDs indicate data transmission (green) and reception (yellow) and a Status LED indicates module energized state (green) and de-energized state (yellow).

The ARIES-MLX is compatible with all SmartOne protocol based devices. The SmartOne communication protocol is called Broadcast Index Polling (BIP). The BIP enables each of the 255 initiating device on the SLC to communicate with the panel on an individual basis in an intelligent system. Each SmartOne initiating device has a microprocessor, memory, and decision-making algorithms to interrupt normal control-unit communications and initiate an alarm signal. The BIP communication protocol divides the potential 255 addresses on the SLC loops into 8 groups of 32 addresses each and the panel constantly samples the groups for fire signatures. Once a fire signature is detected, the panel narrows down to the group with the SmartOne device(s) initiating the signature and further to the particular address initiating the fire signature.

SmartOne addressable detectors include the Model DS-PS photoelectric smoke detector, Model DS-HFS thermal detector, and the Model DS-SD photoelectric duct detector.

The DS-PS is a photoelectric spot detector featuring a bi-color LED with adjustable sensitivity settings from 0.9 to 3.5 % obscuration/ft. The pre-alarm threshold can be set anywhere within the obscuration range of 0.7 to 3.4 percent per foot, but must be less than the detector's alarm threshold.

The DS-HFS is a thermal spot detector featuring fixed temperature heat detection where the alarm threshold is always set to 135°F.

The DS-SD is photoelectric smoke duct detector. It is typically used to detect smoke in the supply side of the HVAC system, but can provide supervision of the return side as well. The DS-SD has a fixed alarm sensitivity of 1.3% to 2.2%/ft obscuration. The pre-alarm level is 75% of the alarm level.

In addition to these detectors other current generation and legacy SmartOne devices are supported on the SLC(s). Examples include: addressable input modules, addressable output modules, remote release modules, addressable signal modules and addressable interface modules to HSSD devices.

SLC EXPANSION CARD SPECIFICATION

Number of Cards:	Subject to slot availability, max 6 per MCB
Circuit Specifications:	Same as SLC on MCB

NACs & R-NACs

The Main Controller Board incorporates two Notification Appliance Circuits and two user-configurable Releasing/Notification Appliance Circuits. The system can be expanded by adding R-NAC cards to the backplane. The Expansion Card occupies a single slot in the Expansion Card Cage Assembly and plugs directly into the backplane. Each R-NAC card provides three Releasing-Notification circuits similar to the R-NAC circuit on the MCB. Given adequate power, the number of R-NAC Expansion Cards in a system is limited only by the availability of card slots – which itself is limited to 24.

Notification Appliance Circuits can be wired as Class A or Class B and support 24 VDC polarized appliances such as horns, strobes and bells. Strobes can be either synchronized or non-synchronized.

The Releasing Circuits can be wired as Class A or Class B and configured to activate agent control heads, actuators or initiators. The circuit-on time is configurable from 55 microseconds, 90 seconds, 10 minutes, 15 minutes, On-To-Reset or custom dependent on the release device and suppression system. While the circuits are power limited, utilizing this option for releasing requires the use of a field In-Line Releasing Device. A disconnect switch provides the means to disable the releasing circuit.

R-NAC EXPANSION CARD SPECIFICATION

Number of Cards:	Subject to slot availability, max 24 per MCB
Number of Circuits Per Card:	Three
Circuit Specifications:	Same as R-NAC on MCB

Triple Redundancy Protection

Unlike some generic fire alarm control units adopted for releasing service, at its core the ARIES-MLX is suppression-focused. Featuring the exclusive Triple-R redundancy safeguard wherein no single component failure or combination of abnormal operating conditions, including main microprocessor failure, is allowed to result in accidental release activation, the ARIES-MLX provides the same high quality, dependability and maximum protection against inadvertent release that have been the hallmark of Kidde suppression panels for decades. The Triple-R system requires that in order to activate a release, the main microprocessor issue two release commands of opposite polarity via separate signaling channels and that these commands combine with a signal from the control unit's watchdog timer to confirm the microprocessor operation. The Triple-R system ensures that electrical transients or disturbances such as power surges that could interfere with the operation of the main microprocessor will not inadvertently activate the connected suppression system. The result is a more robust and reliable suppression control unit.

Relays

The MCB has 3 programmable Form-C relays and 1 dedicated Form-C trouble relay. The 3 programmable relays can change state for alarm, trouble and supervisory conditions. These relays are normally de-energized and will not change state if all power is lost and for certain MCB failures. The 1 dedicated trouble (non-programmable) relay is normally energized and will change state when all power is lost.

Additional relays can be added to the system by adding Relay Cards into the optional card cage. The Relay Card is equipped with 4 Form C floating relay contacts. Each relay is independently-driven and can be programmed to change state for Alarm, Trouble and Supervisory conditions. Red and green/yellow status LEDs are visible from the outside edge of the module. The relays on this card are normally de-energized and will not change state when total power is lost and for certain MCB and communication failures. The number of Relay Cards in a system is limited only by the availability of card slots – which itself is limited to 24.

Relay contacts have the following ratings:

- 3 A at 30 Vdc
- 3 A at 120 Vac

RELAY EXPANSION CARD SPECIFICATION

Number of Cards:	Subject to slot availability, max 24 per MCB
Number of Relays Per Card:	Four

City Tie Card

The optional City Tie Card provides connection and operation for three independently operated signaling circuits used to connect to Municipal Tie inputs as either Local Energy output, Shunt-Type Master Box output or Reverse Polarity output. The City Tie Card occupies a single slot in the Card Cage Assembly and plugs directly into the backplane. The ARIES-MLX allows one City Tie Card per control unit.

CITY TIE CARD SPECIFICATION

Number of Cards:	Max 1 per control unit
Number of Circuits Per Card:	Three
Local Energy Type:	24 VDC @ 550 mA maximum
Shunt-Type Master Box:	24 VDC @ 5 A maximum
Reverse Polarity Type:	24 VDC @ 100 mA maximum

Networking

For large areas or campus style-applications, ARIES-MLX control units can be networked into a powerful system capable of supporting 130,560 addressable devices. The ARIES-MLX has the capability to provide true peer-to-peer networking of up to 64 ARIES-MLX, ARIES NETLink, FENWALNET™ 8000-ML, and Chemetron® MICRO MLX control units (must be version 2.1.2 software or later.)

Added functionality is provided when the Remote Display Control Module (RDCM) are connected to the individual control panels and hence into the interconnection scheme. The network is capable of performing fire-alarm and/or suppression system operations on a network-wide basis:

- Event initiation
- Protected-premises local and/or remote event annunciation
- Occupant notification via audible and visible signaling appliances
- Process/equipment control to activate safety procedures
- Fire extinguishing system release
- Off-premises transmissions to central station or fire department

The network provides several convenient interconnect programming schemes wherein control panels can be configured individually or within created groups of control panels. When utilizing the grouping configuration, the interconnection automatically provides shared alarm and trouble responses. The programmable shared responses are: acknowledge, silence, reset, event logging and logic statements. Operator events can be activated into the interconnection via the control panels or any annunciator. A location address and programmable description is used to identify the panel initiating the event.

The ARIES-MLX meets the Display and Control Centre requirements of ULC S527-11. When configured for "ULC Operation" and networked with other control units, any control unit can become the Display and Control Centre Node. The first node to perform a control type operation - event acknowledge, system reset, system silence or fire drill - gains exclusive control of the network. When a node is in control, all other nodes display an indication of the node in control and, as long as keypad operations continue to be performed, that node remains in control. Control can be relinquished after an inactivity period or another node requests control (by pressing an operational button and selecting "REQUEST CONTROL").

Network Interface Card – NIC

The Network Interface Card regenerates and boosts network communications between control units and electrically isolates the networked units from each other. All ARIES-MLX units must contain a NIC to be networked to one another. The NIC occupies a single slot in the Card Cage Assembly. Using the NIC, the control units transmit and receive messages via RS485 format over a twisted pair. Optional Fiber Optic Converter Modules (FOCM) allows connectivity via a fiber optic medium. The networking structure supports a mixture of fiber-optic and twisted-wire interconnections among networked control units. The network structure also supports up to 4,000 ft. long 18 AWG of copper wire between nodes (control units).

NETWORK INTERFACE CARD (NIC) SPECIFICATION

Number of Cards:	Max 1 per control unit
Number of nodes in network:	Maximum 64
Wiring Classes:	Class A or Class B
Data Ports:	EIA/TIA-485
Baud Rate:	38,400 baud
Recommended Wiring:	AWG 18, twisted, shielded, pair
Maximum Recommended Length:	4,000 ft. (1,219 m)

Fiber Optic Converter Module – FOCM

A fiber-optic option is available for network applications (NIC card also required) with communication paths greater than 4,000 ft., where excessive electrical noise is present or for high security environments that require higher levels of immunity to being tapped. FOCMs are available for multi-mode (MM) and single mode (SM) fiber applications. They are bi-directional, externally-powered units which are wall mountable in the standard Kidde ARIES-MLX remote enclosure. One FOCM is required at both interconnected ARIES-MLX control units for a single communication channel.

For short transmission distances (under 1 mile), such as within a building or on a campus, multi-mode optical fiber (MM fiber) can be used (62.5 µm core size/125 µm cladding diameter). For longer transmission distances (up to 12 miles), single-mode (SM fiber) can be used (8.3 µm core size/125 µm cladding diameter).

The FOCMs are shipped standard with one converter channel. For greater communication security and redundancy, a second converter channel may be added. This is most effective if the second channel is installed in a different pathway from the first.

FIBER OPTIC CONVERTER MODULES (FOCM) SPECIFICATION

Operating Voltage:	24 VDC
Operating Current:	0.0380 A (Single Mode) 0.0369 A (Multi Mode)
Data Ports:	EIA/TIA-485
Max. Recommended Length for MM Fiber:	1 mile (with no more than 6.4 dB/mile cable attenuation)
Max. Recommended Length for SM Fiber:	12 miles (with no more than 1.66 dB/mile cable attenuation)
Baud Rate:	38,400 Baud
Temperature Range:	0° to 50°C
Humidity Range:	0 to 93% RH, non-condensing
Enclosure Dimensions (H x W x D):	7-1/2 x 12-3/4 x 2-3/4 (in.) 191 x 324 x 70 (mm)

Digital Alarm Communicator Transmitter – DACT

The communication capabilities of the ARIES-MLX control unit are enhanced with an optional DACT which transmits system status over phone lines to a Central Station. The DACT card includes a built-in modem and two Loop Start Public Switched Telephone Network (PSTN) connections. Status LEDs are provided to indicate data transmission (green) and reception (yellow). An ARIES-MLX system allows one DACT Card per control unit. The DACT card operates on 24 Vdc and supports SIA DC-05-1999.09 Ademco Contact ID and SIA DC-03-1990.01 (R2003.10) protocols. For compliance to UL 864 10 edition, additional third party communicators may be required depending on the installation location.

DIGITAL ALARM COMMUNICATOR TRANSMITTER (DACT) SPECIFICATION

Number of Cards:	Max 1 per control unit
Operating Voltage:	24 VDC
Operating Current:	37 mA
Electrical Interface:	PSTN line using a RJ45X phone jack
Supported Protocols:	SIA DC-05-1999.09 Ademco Contact ID SIA DC-03-1990.01 (R2003.10)
Compatible Digital Alarm Communicator Receivers (DACRs):	Sur-Gard System I, Sur-Gard System III and Osborne Hoffman Model 2000E

Internet Communications Module – ICM

The Internet Communications Module (ICM) can be used to access the ARIES-MLX via the Internet to view system status and current events and to download the history log. The ICM can be programmed to transmit up to five e-mails upon the occurrence of any unsolicited event in the system. The e-mail message embeds a link with the IP address of the control unit that sent the message for instant access to the remote system. The ICM can be accessed using standard Web browsers: Internet Explorer or Mozilla Firefox. The ICM also allows the ARIES-MLX control unit to report as a slave device via the Modbus TCP/IP Protocol to a master monitoring system for automated process control.

INTERNET COMMUNICATIONS MODULE (ICM) SPECIFICATION

Operating Voltage:	24 VDC
Operating Current:	42 mA
Operating Environment:	32° to 120°F (0° to 49°C) 0-90% RH, non-condensing
Data Port:	RJ45
Supported Field Protocols:	Ethernet - Local Area Network or Wide Area Network (LAN or WAN)

BACnet Interface

The BACnet Interface module provides protocol translation between the ARIES-MLX communication protocol configure for Modbus and the BACnet IP or MS/TP communication protocol of an external monitoring system such as a building automation system. The communication flow is one-way from the ARIES-MLX network to the external monitoring system. P/N 76-800300-007 includes a single module inside a remote enclosure and supports 4 SLCs (loops 1-4), 50 C state variables and 127 HSSD devices. P/N 76-800300-017 is an additional BACnet module that support loops 5 through 8.

Modbus/BACnet SPECIFICATION

Electrical Connections:	<ul style="list-style-type: none">• 6-pin Phoenix connector, RS232• 3-pin Phoenix connector, RS485• Ethernet-10/100 port
Enclosure Dims (H x W x D):	7-1/2 x 12-3/4 x 2-3/4 (in.) 191 x 324 x 70 (mm)
Operating Voltage:	9-30VDC or 12-24VAC
Operating Current:	170 - 240 mA @ 12 VDC 100 - 140 mA @ 24 VDC 80 - 100 mA @ 30 VDC
Operating Temperature:	-40F to 187F (-40C to 85C)
Humidity:	5 - 90% RH, non-condensing
Data Ports:	RS232, Ethernet
Max. RS232 Cable Length:	50 ft. (15.2 m)
Supported Baud Rate for BACnet MS/TP:	9.6 - 76.8K baud

Enclosures

The ARIES-MLX offers two enclosure sizes, 2-Tier and 3-Tier, for both main and expansion enclosures. The enclosures accommodate the MCB, PMU/PSU, Expansion Card Cages and Batteries. The enclosures are sized to fit between standard 16"-spaced wall studs and can accommodate a pair of 12 VDC12-AH or 17-AH SLA batteries (max. 40-AH). The enclosures are painted red, rated NEMA 1 and constructed from 16 AWG cold rolled steel per ASTM A-366. All Kidde enclosures utilize a common key. Despite its compact dimensions, the enclosure allows a minimum of 1.5 in. (38 mm) of wiring space between the wall and any wiring terminal. Multiple knock-outs provide flexibility in wiring entry.

Dead Front Covers

A sheet-steel dead-front cover may optionally be mounted between the door and electronics to prevent unwanted access to the electronics. With the dead-front installed, an operator has access only to the user interface. A blanking plate (included) may be removed if an integrated LED Annunciator is present. The dead front is typical in ULC/cUL applications.

Enclosure Trim Ring

A sheet-steel red-enamel finished trim ring may be mounted around a semi-flush ARIES-MLX enclosure to enhance the control unit's aesthetic appeal after installation.

Material of Construction:	16 gauge (0.053 in. or 1.35 mm) rolled sheet steel
Enclosure Rating/ Degree of Protection:	NEMA 1
Color:	Red
Enclosure Dimensions (H x W x D):	
• 3-Tier:	31-1/2 x 14-3/8 x 5-3/8 (in.) 800 x 365 x 137 (mm)
• 2-Tier:	22-1/2 x 14-3/8 x 5-3/8 (in.) 572 x 365 x 137 (mm)
Dead Front Dimensions (H x W):	
• 3-Tier:	31-1/3 x 14 (in.) 796 x 356 (mm)
• 2-Tier:	22-5/8 x 14 (in.) 567 x 355 (mm)
Trim Ring Dimensions:	
• 3-Tier:	17-1/2 x 34-5/8 (in.) 444 x 879 (mm)
• 2-Tier:	17-1/2 x 25-5/8 (in.) 444 x 651 (mm)

CONTROL UNIT FEATURES

Seamless Integration with Specialty Detectors

SmartOne loop protocol interface cards enable the ARIES-MLX to seamlessly integrate with specialty detectors. AIR-Intelligence Air Sampling Smoke Detectors (ASD) connect via Addressable Protocol Interface Cards (APIC) and report pre-alarms and alarms in a manner analogous to SmartOne smoke detectors.

Fixed Temperature Linear Heat Sensor cables (LHS) connect via Addressable Input Modules (AI) and report point alarms.

Field Programming Options

The ARIES-MLX Configuration Tool (ACT-MLX) tool is used to program the control unit for each individual site-specific application. Programming is for control-by-event scenarios and consists of entering a series of conditional control statements that logically join initiating points to control-unit-based outputs and remote control modules. Each SmartOne field device can be assigned a location message of up to 40 characters via the configuration tool. A USB Device Port is available to connect a laptop computer for application upload. A USB isolator must be used in series with the USB cable when connecting to USB port, J6.

The ARIES-MLX provides programming flexibility to prohibit the silencing of releasing service signals via the <SIGNAL SILENCE> key and to set the maximum automatic delay for the release operation in accordance with ULC S527-11 requirements. A Releasing Service Signal Silence Station is available for purchase and should be installed near the control unit in these applications.

An *AutoLearn* routine that creates a general alarm (one-input-activates-all outputs) application can be invoked from the User Interface to speed the configuration process. A more sophisticated *Auto-Setup* routine which automatically configures the control unit for a typical waterless fire-suppression system can also be invoked.

Automatic SLC Device Testing

The ARIES-MLX features an exclusive automatic SLC device testing protocol. With this cutting edge supervisory technology, the control unit routinely checks all SLC devices in groups of 32 for operational status. If a group fails, the control unit then interrogates at lower level in that group and pin-points and reports the malfunctioning device on the User Interface within seconds.

Duplicate Address Detection

Electronic device addressing is via the Handheld Programmer (HHP). The fully-digitized ARIES-MLX control unit protocol has the ability to monitor the SLC for devices with duplicate addresses. Should such duplication be detected, the control unit displays these addresses on the User Interface – thereby reducing the overall configuration time.

Battery Life Tracking

The ARIES-MLX software includes an optional Battery Monitoring Mode which can track battery lifetime from the original install date and emit an audible signal on the replacement due date.

Annunciator Bus

The Main Controller Board includes an RS-485 bus which can communicate with up to a total of 31 Remote Annunciators. These include up to 15 RDCM Remote Display/Control Modules and up to 16 of the following remote modules: Remote LED Annunciator Module (R-LAM), Model ATM-L LED driver module and Model ATM-R Relay driver module.

CONTROL UNIT ACCESSORIES

Large Capacity Battery Cabinet

An optional NEMA-1 surface-mount Battery Cabinet is available for a pair of up to 12 VDC 40-AH sealed lead acid batteries. The cabinet is designed to be located within 100 feet of the control unit. The red painted cabinet is constructed of cold-rolled steel as other available Kidde enclosures. The door is hinged on the left and includes the same lock and key used with all Kidde enclosures. Three conduit knockouts are provided at the top to accommodate either ½ inch or ¾ inch standard electrical conduit fittings.

REMOTE BATTERY ENCLOSURE SPECIFICATION

Accommodates:	Up to 2 x 12 VDC 12-AH (max 40 AH)
Material of Construction:	18 Gauge (0.053 in. or 1.35 mm) rolled sheet steel
Enclosure Rating/Degree of Protection:	NEMA 1
Color:	Red
Enclosure Dimensions (H x W x D):	12 x 20 x 8-1/4 (in.) 305 x 508 x 210 (mm)

REMOTE ANNUNCIATORS

Remote Display Control Module - RDCM

RDCMs are user interfaces that replicate the ARIES-MLX user interface and can be located remotely from the main control unit to accomplish system control from multiple locations. RDCMs display all system events and allow full system control and operator intervention via an LCD display, keypad, buzzer, five (5) system status LEDs and four (4) user-programmable soft-keys. A synchronization signal output allows expansion of up to 15 RDCM units. RDCMs are wall mountable in their own discrete enclosures and operate on 24 VDC sourced from either the ARIES-MLX Auxiliary Power Output or listed external power supply.



Figure 4. RDCM

REMOTE DISPLAY CONTROL MODULE (RDCM) SPECIFICATION

Number of RDCMs:	Max 15 on Annunciator Bus
Power Input:	150 mA maximum @ 24.0 VDC
Input Capacitance:	100 µF max.
PMU Trouble Relay Input:	Short = normal; open = fault
Synch In/Out:	3.3 VDC Logic
Wiring Type:	EIA/TIA-485, twisted shielded pair, maximum capacitance 15 pF per ft.
Wiring Minimum Size:	AWG 18
Maximum wire length:	4,000 ft. (1,219 m)

Remote LED Annunciator Module - R-LAM

R-LAMs are annunciators that provide 48 independently programmable LEDs. Each LED is dual color (red and yellow) and has space available for an identification label. R-LAMs include three system-level LED outputs for Module Power, System Trouble and Signal Silenced. Also included are system-level input functional switches for Signal Silence and System Acknowledge/Self-Test commands. R-LAMs are mounted remotely from the main enclosure and utilize the same remote enclosures as do RDCMs. LED Annunciator Modules can also be mounted within the main ARIES-MLX enclosure for ULC/cUL applications.



Figure 5. R-LAM

REMOTE LED ANNUNCIATOR (R-LAM) SPECIFICATION

Number of Modules:	Max 16 on Annunciator Bus; 15 if LAM integrated into control unit
Power Input:	150 mA maximum @ 24.0 VDC
Input Capacitance:	100 µF max.
PMU Trouble Relay Input:	Short = normal; open = fault
Synch In/Out:	3.3 VDC Logic
Wiring Type:	EIA/TIA-485, twisted shielded pair, maximum capacitance 15 pF per ft.
Wiring Minimum Size:	AWG 18
Maximum Wire Length:	4,000 ft. (1,219 m)

REMOTE ANNUNCIATOR ENCLOSURE SPECIFICATION

Accommodates:	1 RDCM 1 R-LAM
Material of Construction:	18 Gauge (0.053 in. or 1.35 mm) rolled sheet steel
Enclosure Rating/Degree of Protection:	NEMA 1
Color:	Red
Enclosure Dimensions (H x W x D):	7-1/2 x 12-3/4 x 2-3/4 (in.) 191 x 324 x 70 (mm)

RETROFITTING LEGACY INSTALLATIONS

Legacy PEGAsys Control Unit Retrofit Kit

Installed PEGAsys and FenwalNET™ 2000 control units can be upgraded to ARIES-MLX level by utilization of a retrofit kit. The retrofit kit consists of ARIES-MLX electronics, power supply and a door (either red or beige) for the installed PEGAsys/FenwalNET 2000 enclosure. The kit enables the PEGAsys/FenwalNET 2000 electronics to be replaced without disturbing the original enclosure-backbox and conduits; thus maintaining the customers' investment in devices, suppression and wiring. The retrofit door is sized for the PEGAsys/FenwalNET 2000 enclosure while its window is aligned with the ARIES-MLX. The retrofit kits consist of following parts.

ARIES-MLX RETROFIT KIT PARTS

• Base Plate	qty. 1
• Base Plate Bracket	qty. 1
• Replacement Door	qty. 1
• Retrofit Installation Hardware	qty. 1
• PSU with wiring harness to PMU Board	qty. 1
• PMU Installation Hardware Kit	qty. 1
• MCB, complete with UI and mounting hardware	qty. 1
• MCB Installation Hardware Kit	qty. 1

OPTIONAL ADD-ONS TO BOTTOM TIER OF LEGACY BACKBOX: (room for only one from list below)

• Card Cage Assembly with backplane, bracket, hardware and cables, P/N 76-800010-001	qty. 1
• Additional PSU/PMU Assembly with bracket and hardware, P/N 76-800030-003	qty. 1
• Standby Batteries	one pair

ORDERING INFORMATION

Part Number	Description
ARIES-MLX SYSTEMS	
77-800100-901	ARIES-MLX Control Unit-3T (for use in USA only)
76-800100-901	ARIES-MLX Control Unit-3T (for use outside USA only)
77-800101-902	ARIES-MLX Control Unit-3T-ULC (for use in USA only)
76-800101-902	ARIES-MLX Control Unit-3T-ULC (for use outside USA only)
77-800200-901	ARIES-MLX Control Unit-2T (for use in USA only)
76-800200-901	ARIES-MLX Control Unit-2T (for use outside USA only)
77-800201-902	ARIES-MLX Control Unit--2T-ULC (for use in USA only)
76-800201-902	ARIES-MLX Control Unit--2T-ULC (for use outside USA only)
EXPANSION ENCLOSURES	
76-800100-903	ARIES-MLX Expansion Encl-3T
76-800200-903	ARIES-MLX Expansion Encl-2T
ENCLOSURE TRIM RINGS	
76-800100-004	ARIES-MLX Trim Ring-3T Enclosure
76-800200-004	ARIES-MLX Trim Ring-2T Enclosure
76-800300-004	ARIES-MLX Trim Ring-RDCM Enclosure
EXPANSION CARDS	
76-800011-001	ARIES-MLX SLC Card
76-800012-001	ARIES-MLX Relay Card
76-800013-001	ARIES-MLX R-NAC Card
76-800016-001	ARIES-MLX City Tie Card
76-800015-001	ARIES-MLX DACT Card
76-800017-001	ARIES-MLX ICM Card
76-800014-001	ARIES-MLX NIC Card
EXPANSION CARD CAGE	
76-800010-001	ARIES-MLX Card Cage Assy
76-800010-002	ARIES-MLX Backplane Board
REMOTE ANNUNCIATORS/MODULES	
76-800300-901	ARIES-MLX Remote Display Control Module
76-800300-902	ARIES-MLX Remote LED Annunciator
76-200004-032	ARIES-MLX ATM-L LED Driver Module
76-200005-032	ARIES-MLX ATM-R Relay Driver Module
STANDBY BATTERIES (order 2 for 24V)	
06-115915-013	Battery, 12 Vdc, 7-AH
06-115915-047	Battery, 12 Vdc, 12-AH
06-115915-046	Battery, 12 Vdc, 17/18-AH
89-100052-001	Battery, 12 Vdc, 35-AH (requires large capacity battery cabinet)
76-100010-001	Large Capacity Battery Cabinet, Red
76-800030-006	ARIES-MLX Battery Tray

ORDERING INFORMATION (Continued)

Part Number	Description
EXTERNAL MODULES	
76-800300-005	ARIES-MLX FOCM w/enclosure, for MM fiber
76-800300-006	ARIES-MLX FOCM w/enclosure, for SM fiber
76-800300-015	ARIES-MLX FOCM Add-On Converter Channel, for MM fiber
76-800300-016	ARIES-MLX FOCM Add-On Converter Channel, for SM fiber
76-800300-007	ARIES-MLX BACnet Module with enclosure
76-800300-017	ARIES-MLX BACnet Module Add-On Card
REPLACEMENT ENCLOSURES AND COVERS	
76-800101-005	ARIES-MLX Dead Front-3T
76-800201-005	ARIES-MLX Dead Front-2T
76-800100-931	ARIES-MLX 3T Main Enclosure
76-800200-921	ARIES-MLX 2T Main Enclosure
76-800101-901	ARIES-MLX 3T Main Enclosure ULC
76-800201-901	ARIES-MLX 2T Main Enclosure ULC
76-800300-941	ARIES-MLX Remote Display Enclosure
MCB & KEYPAD/DISPLAY	
76-800020-003	ARIES-MLX Replacement LAM Board
76-800020-901	ARIES-MLX Main Controller Board
76-800020-002	ARIES-MLX Keypad-Display
POWER SUPPLIES	
76-800030-001	ARIES-MLX PSU 120-240VAC 5.4A without harness to PMU Board
76-800030-002	ARIES-MLX Power Supply, 120-240VAC 5.4A with harness
76-800030-004	ARIES-MLX PMU Board
76-800030-003	ARIES-MLX Add -on Power Supply/PMU Assembly
76-800030-005	ARIES-MLX PMU Assy Mounting Bracket
76-800030-007	ARIES-MLX PMU Fuse Kit
MISCELLANEOUS	
76-800000-001	ARIES-MLX Installation-Hardware Universal
76-800000-004	ARIES-MLX In-Line Releasing-Circuit Device, Class A wiring
06-220023-001	In-Line Releasing-Circuit Device, Class B wiring
76-800000-902	ARIES-MLX Main Plexiglass Window
76-800000-903	ARIES-MLX R-LAM Plexiglass Window
76-800000-005	ARIES-MLX Bezel-Enclosure Door
76-800000-006	ARIES-MLX Harness Enclosure-to-Enclosure
76-800000-009	ARIES-MLX Multi-Loop Seismic Conversion Hardware Kit for Enclosures
76-800000-010	ARIES-MLX Multi-Loop Seismic Conversion Hardware Kit for Large Capacity Battery Cabinet
70-600000-101	Hand-Held Programmer, Complete Kit

COMPATIBLE DEVICES

SmartOne SLC DEVICES

Part Number	Description
DS-PS	Model DS-PS Photoelectric Detector
DS-HFS	Model DS- HFS 135 F (57 C) fixed temperature heat (thermal) detector
DS-SB	Model DS-SB Standard base for DS-PS and DS-HFS detectors
DS-RB	Model DS-RB Relay Base for DS-PS and DS-HFS detectors
DS-SD	Model DS-SD Photoelectric Duct Detector
SD-T8	8-inch sample tube
SD-T18	18-inch sampling tube
SD-T24	24-inch sampling tube
SD-T36	36-inch sampling tube
SD-T42	42-inch sampling tube
SD-T60	60-inch sampling tube
SD-T78	78-inch sampling tube
SD-T120	120-inch sampling tube
70-417008-002	AI Monitor Module (N/C) (UL only)
70-417018-001	AI Monitor Module for normally-open initiating device
85-100000-100	Control Head Monitor (CHM)
70-408004-001	AO Relay/Control Module
70-408014-001	AO Relay/Control Module (non-silicone)
77-297103-000	PEGAsys Addressable Loop Module (Fits in ORION XT Detector)
70-200200-003	Addr. Signal Module
74-200012-002	Isolator Module (single-gang mount)
74-200012-004	Isolator Module (detector-base mount)
70-600000-001	Remote Releasing Module (standard mount)
70-600000-002	Remote Releasing Module (in-cabinet mount)
76-333002-001	APIC for AIR-Intelligence ASDs
84-330002-001	Addr. Dual Action Pull Station with integral Model AI Addressable Monitor Module
84-878752-010	Suppression Abort Station (requires a Model AI Addressable Monitor Module)
84-878752-110	Abort Station for ULC applications (requires Model AI Addressable Monitor Module)
76-800600-101	Canadian Releasing Service Signal Silence Station (includes Faceplate with Key Switch, Backbox, and N.O. Model AI Addressable Monitor Module)

RELEASING DEVICES - ACTUATOR-BASED

Devices	Max. Number per R-NAC Circuit or RRM	Agency
83-132500-500*	1	FM
83-131082-001*	1	FM

*The circuit resistance for this device must be 10 + 1 ohms. The firing current will be 2.5 Amps.

RELEASING DEVICES - INITIATOR-BASED

Devices	Max. Number per R-NAC Circuit or RRM	Agency
93-002009-004**	8	FM
31-199932-004*	12	UL, FM
93-191001-001*	6	UL, FM

*The circuit resistance for this device must be 10 + 1 ohms. The firing current will be 2.5 Amps.

**The total circuit resistance for the 31-199932-004 and 93-191001-001 devices must be 10 + 1 ohms, regardless of the number used. The total circuit resistance (including field wiring) for the 93-002009-004 device should be adjusted to be at least 10 ohms, not to exceed 13.6 ohms. The firing current will be 2.5 Amps.

sales@norrscope.com