

PART NO.	VALVE TYPE	VALVE SIZE	A	B	C	WEIGHT	INLET THREAD	OUTLET THREAD
B6793-793	40	40mm (1½")	194mm	123mm	133mm	4.5kg	2.500-12 UN-2B	1.875-12 UN-2B
B6793-792	50	50mm (2")	224mm	135mm	160mm	6.8kg	3.000-12 UN-2A	2.500-12 NPT
K63536-01	65	65mm (2½")	255mm	160mm	168mm	10.8kg	3.500-12 UN-3A	N/A

**MATERIALS:**

VALVE BODY & PISTON: BRASS (NATURAL FINISH)  
 VALVE SEAT: RUBBER

**VALVE DATA:**

WORKING PRESSURE: 25 to 42 bar  
 PROOF PRESSURE: 69 bar  
 BURST PRESSURE: 138 bar  
 TEMPERATURE RANGE: -18°C to +55°C

SAFETY DISC RATED TO: 55 bar NOMINAL  
 GCV 50 SAFETY DISC IS CYLINDER MOUNTED



ALL DIMENSIONS IN mm's UNLESS OTHERWISE STATED

4	2.08.10	UL MARK ADDED DCN10-037	
3	28.09.04	REVIEW AND REISSUE	
2	27.06.96		
REV	DATE	REASON FOR ISSUE	APP

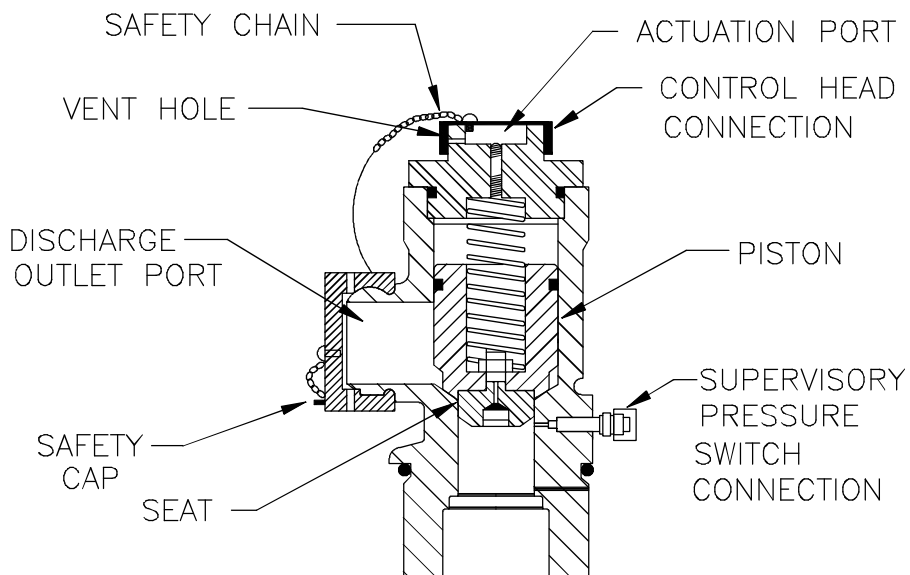
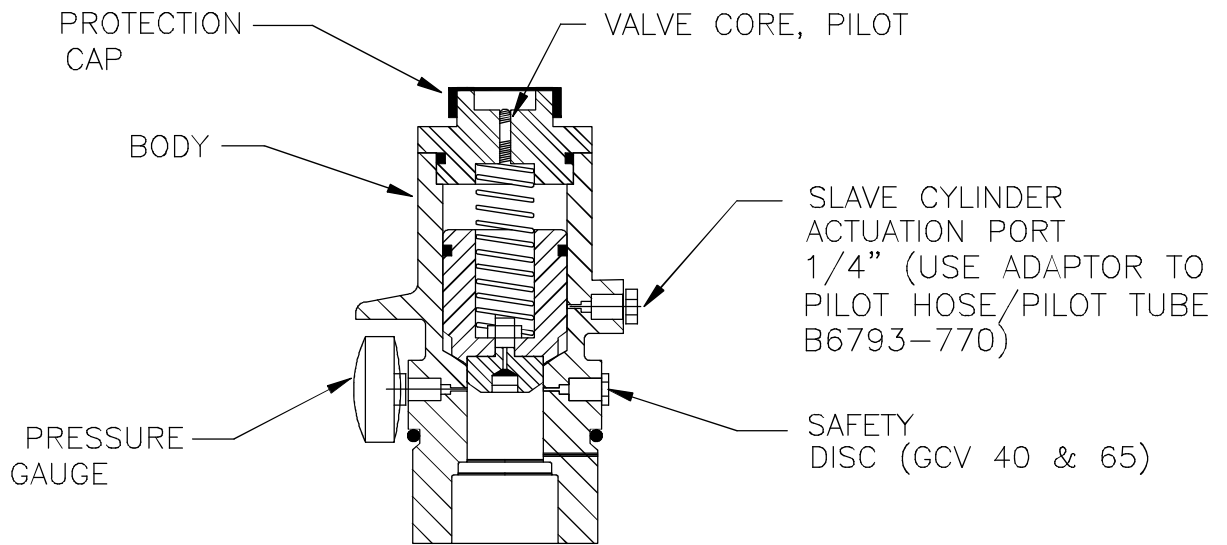

GX20 Systems

sales@norrscope.com



4	2.08.10	UL MARK ADDED DCN10-037	
3	28.09.04	REVIEW AND REISSUE	
2	27.06.96	—————	
REV	DATE	REASON FOR ISSUE	APP

ALL DIMENSIONS IN mm's UNLESS OTHERWISE STATED