

Drawn / Date MA 26/11/99	App. by / Date RK 26/11/99	Date of issue 12/02/21	Rev. 7	DCN 19-076
-----------------------------	-------------------------------	---------------------------	-----------	---------------

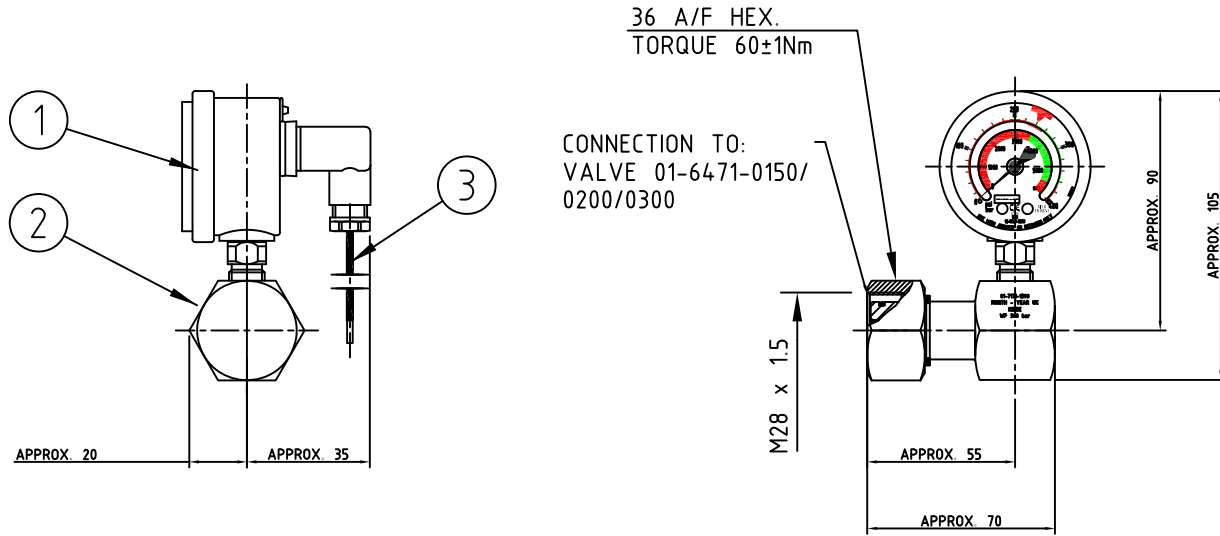

NOMINAL PRESS, bar	SCALE x100kpa, bar	MAX WORKING PRESS, bar	TEST PRESS, bar	NORMALLY CLOSED, bar	NORMALLY OPEN, bar	KIDDE Part no.:
150	120-250	178	270	≥ INCR. 120	< DECR. 120	01-7171-1150
200	160-315	240	360	≥ INCR. 160	< DECR. 160	01-7171-1200
300	240-400	370	555	≥ INCR. 240	< DECR. 240	01-7171-1300

DECR. = DECREASE, INCR.= INCREASE

- 1. CONTACT PRESSURE GAUGE CONTACT : STAINLESS STEEL CASING  
 : GOLD PLATED  
 VOLTAGE 4.5 - 24V DC/VAC  
 CURRENT 5 - 100mA  
 CONTACT LOAD 2.4W Max.
- DIAMETER : ø55mm  
 ACCURACY CLASS : 1.6 IN SCALE  
 WEATHER PROTECTION : IP 65 (DIN 43650)
- 2. BLOCK : BRASS  
 SPARE O-RING : PART NO. 15-0181-0300
- 3. SINGLE CORE CABLE : 1.5 mm<sup>2</sup> x 500mm INCL. SILICONE RUBBER, RED IEC 228 CLASS 5
- TEMPERATURE RANGE : -20°C TO 50°C (ISO 14520/EN 12094)  
 -29°C TO 55°C (NFPA 2001/UL 2127)

WEIGHT APPROX.

: 0.7 kg

[sales@norrscope.com](mailto:sales@norrscope.com)